

ADAPTING THE PAT-4 PHONO PREAMP REPLACEMENT (PAT4PPR) FOR USE IN A PAT5 PREAMP

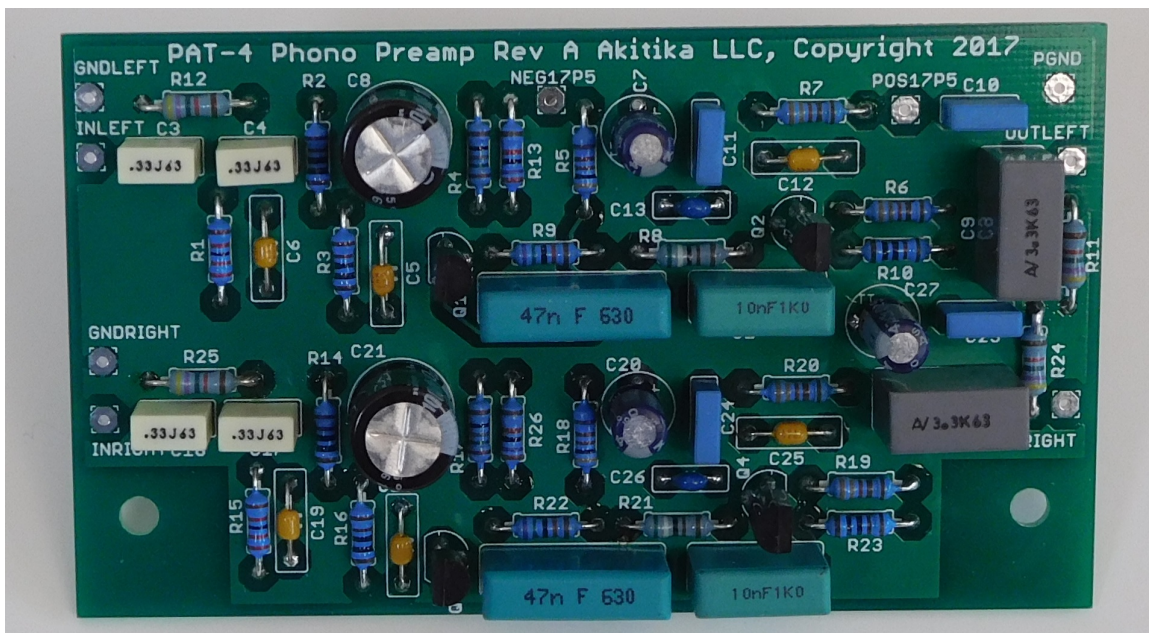

© 2017 Akitika, LLC

All rights reserved

Revision 1p01

February 8, 2017

Table of Contents

| | |
|------------------------------------|---|
| Table of Contents | 2 |
| Table of Figures | 2 |
| Section 1: About This Manual | 3 |
| PCB Loading Changes | 3 |
| Powering Changes | 3 |

Table of Figures

| | |
|--|---|
| Figure 1-Schematic showing value changes for PAT-5 application, page 1 | 4 |
| Figure 2-Schematic showing value changes for PAT-5 application, page 2 | 5 |

Section 1: About This Manual

This manual gives the information you need to convert the PAT-4 Phono Preamp for use in a PAT5. The power supply voltages applied will be different, and some values loaded into the PCB will change. Please refer to the PAT-4 PPR manual, and then implement the changes described in the following sections.

PCB Loading Changes

The following different component values are loaded when you adapt the PAT4PPR for use in a PAT-5 preamp.

| Desig | PAT4 value | PAT5 value | Color code for PAT5 value | Done✓ |
|-------|------------|------------|---|-------|
| R13 | 27K | 18K7 | Brown, gray, violet, red, brown | |
| R26 | 27K | 18K7 | Brown, gray, violet, red, brown | |
| R6 | 3320 | 4K99 | Yellow, white, white, brown, brown | |
| R19 | 3320 | 4K99 | Yellow, white, white, brown, brown | |
| R7 | 3320 | 30K1 | Orange, black, brown, red, brown | |
| R20 | 3320 | 30K1 | Orange, black, brown, red, brown | |
| R5 | 30K1 | 49K9 | Yellow, white, white, red, brown | |
| R18 | 30K1 | 49K9 | Yellow, white, white, red, brown | |
| C7 | 25V | 50V | Both are 47 uF, but the PAT5 rating should 50 Volts | |
| C20 | 25V | 50V | Both are 47 uF, but the PAT5 rating should 50 Volts | |
| C27 | 25V | 50V | Both are 47 uF, but the PAT5 rating should 50 Volts | |

Powering Changes

Here are the powering changes:

1. Connect the POS17P5 eyelet of the new phono preamp PCB to the 42 volt DC supply on the PAT5 power supply.
2. Connect the NEG17P5 eyelet of the new phono preamp PCB to the -15 volt DC supply on the PAT5 power supply.

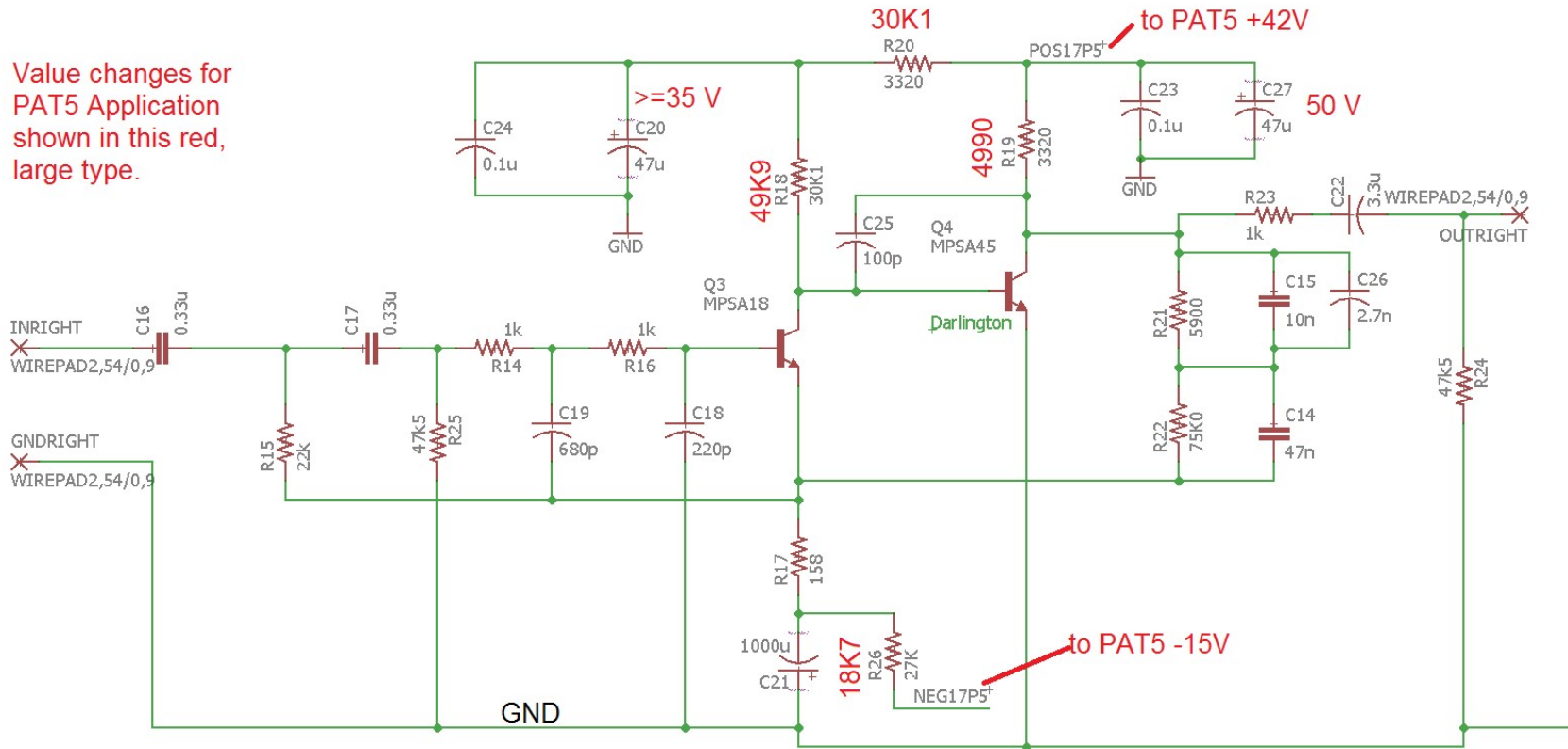
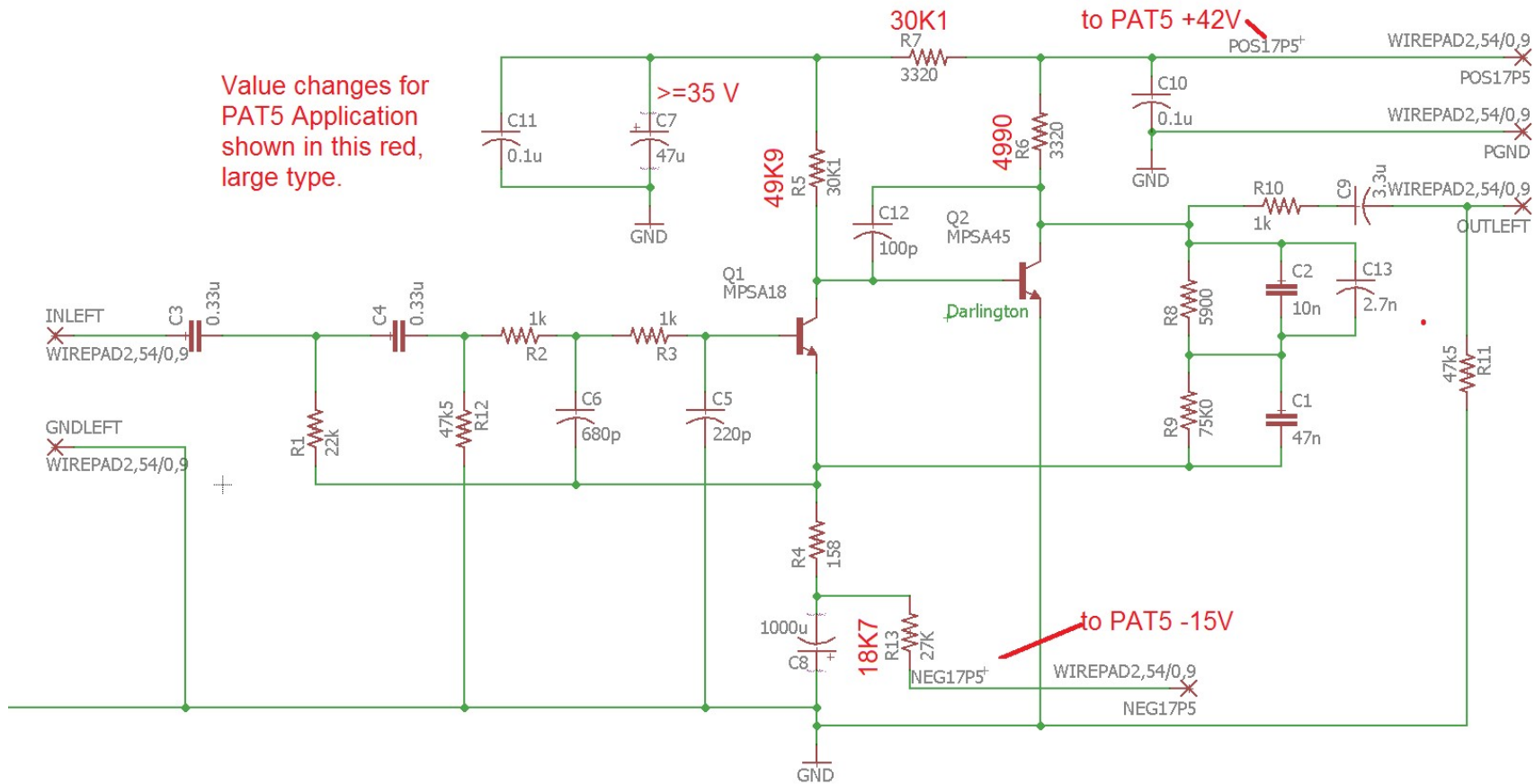

Figure 1-Schematic showing value changes for PAT-5 application, page 1



Value changes for PAT5 Application shown in this red, large type.

to PAT5 +42V

to PAT5 -15V

Figure 2-Schematic showing value changes for PAT-5 application, page 2