

dynaco

SCA-50 AMPLIFIER

SERIAL NUMBER

This number must be mentioned in all communications concerning this equipment.

INSTRUCTIONS FOR ASSEMBLY OPERATION



929053-1

dynaco inc.

COLES ROAD & CAMDEN AVENUE / POST OFFICE BOX 88
BLACKWOOD, N. J. 08012, U.S.A.

CONTENTS

Specifications	2	Voltages	20
Introduction	3	In Case of Difficulty	21
Operating Instructions	3	Circuit Board Layouts	22
Installation Instructions	5	Service Policy and Limited Warranty	22
Assembly Instructions	6	240 Volts AC Line Connections	23
Back Panel Assembly	7	Parts List.....	24
Front Panel Assembly	9	Photo of Completed Unit	Insert
Main Chassis Assembly.....	11	Functional Block Diagram	Insert
Final Wiring	18	Circuit Description	Insert
Schematic Diagram	12 & 13	Pictorial Diagram.....	Insert
Component Values	14		

CAUTION: For continued protection, replace power fuse with the same type and rating as indicated.

WARNING: TO PREVENT FIRE OR SHOCK HAZARD, DO NOT EXPOSE THIS EQUIPMENT TO RAIN OR MOISTURE.

SPECIFICATIONS

Rated Power Output:

25 watts continuous average power per channel into 8 ohms, 20-20,000 Hz, at less than 0.25% total harmonic distortion. Distortion decreases at lower power outputs.

Power at Clipping, Single Channel, 1000 Hz, less than 1% distortion:

35 watts @ 8 ohms; 35 watts @ 4 ohms; 20 watts @ 16 ohms.

Intermodulation Distortion:

Less than 0.1% at any power level up to 25 watts rms per channel into 8 ohms with any combination of test frequencies. Distortion decreases at lower outputs.

Frequency Response:

Phono: ± 1 dB of RIAA curve @ 1 watt into 8 ohms.
High Level: ± 0.5 dB, 15 Hz to 45 kHz @ 1 watt into 8 ohms.

Hum and Noise:

Phono: 72 dB below a 10 mv input (Ref: 1 kHz).
High Level: 89 dB below a 0.5 v input.

Input Sensitivity:

Phono: 1.65 mv for 25 watts output.
High Level: 125 mv for 25 watts output.

Phono Input Overload:

100 mv @ 1000 Hz.

Tone Controls:

± 10 dB @ 50 Hz; ± 10 dB @ 15 kHz

Impedances:

Magnetic Phono: 47,000 ohms.
High Level: 50,000 ohms.
Tape Output: From Phono inputs, 10,000 ohms minimum load.
From High Level inputs, same as source.
Headphone Output: 4 ohms or greater.

Separation:

60 dB @ 1000 Hz minimum; 40 dB @ 10,000 Hz.

Semiconductor Complement:

17 transistors, 2 integrated circuits, 2 FET's, 24 diodes.

Dimensions:

13½" wide x 12" deep x 4¼" high.

Shipping Weight:

15 lbs.

Power Consumption:

20 watts quiescent; 240 watts maximum; 50/60 Hz, 120 or 240 VAC.

TYPICAL PERFORMANCE CURVES

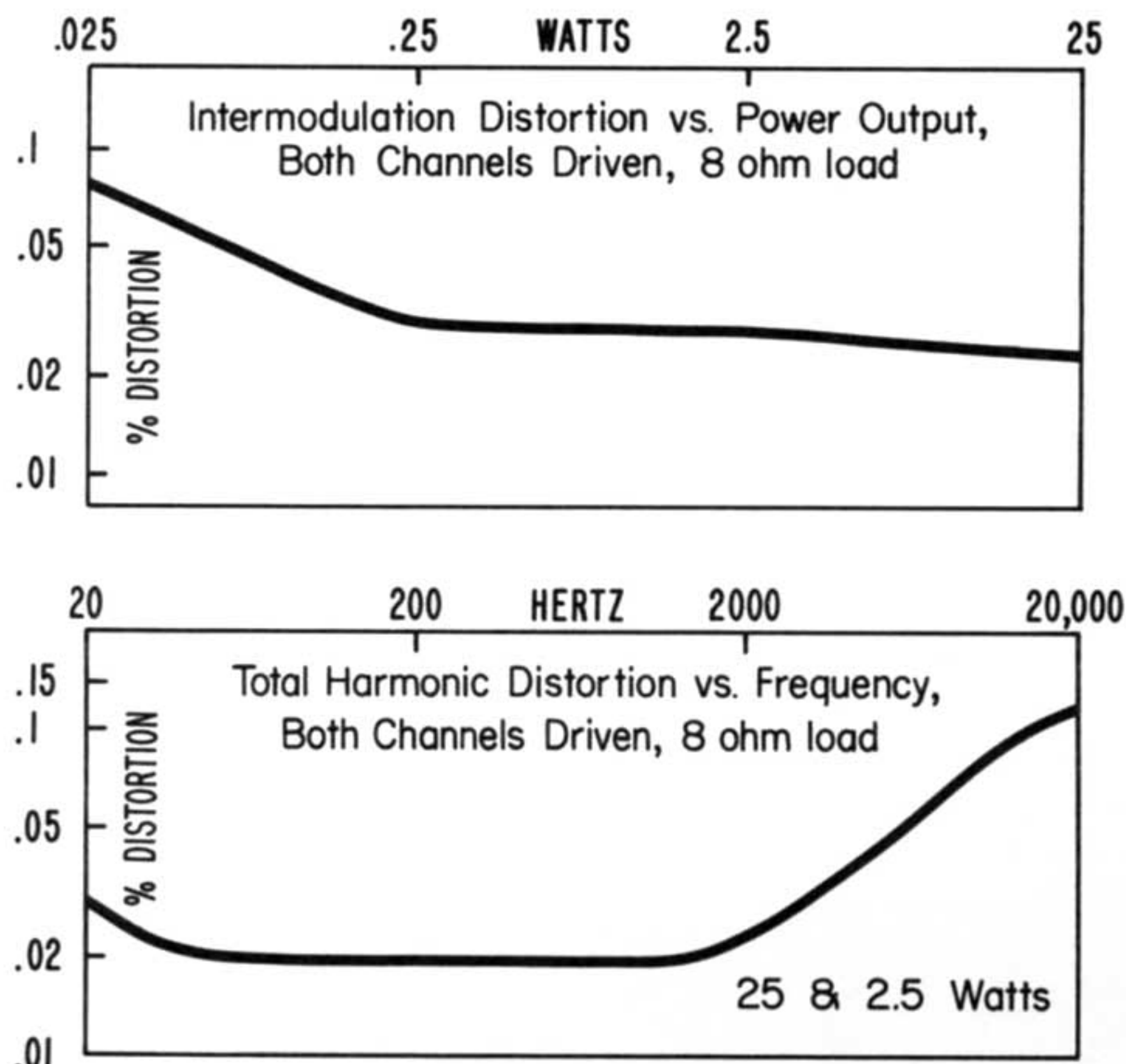

TONE CONTROL RANGE

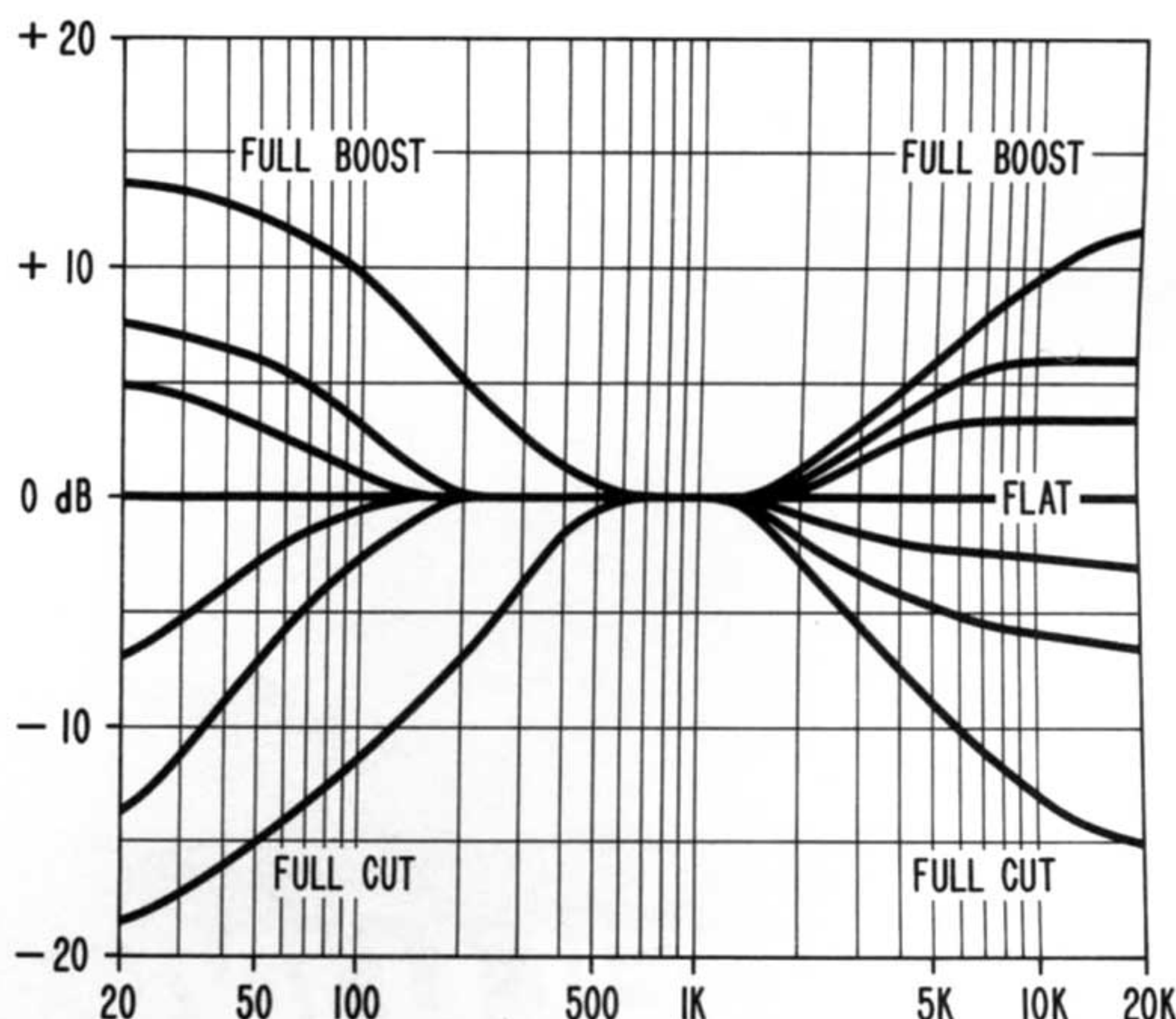

INTRODUCTION

The Dynaco SCA-50 is a medium power solid state stereo control amplifier of exceedingly high quality. Thorough planning has provided flexibility in a full function control center with remarkable simplicity and operating ease. A high gain RIAA-equalized magnetic phono input is accompanied by 4 high level inputs for accommodating a radio tuner, 2 tape recorders, and television sound or similar signals. Two constant level tape outputs are provided ahead of the volume and tone controls, with monitoring access on one of them. A front panel headphone output is in addition to switch-selected main and remote stereo speakers.

The components of the SCA-50 are of notably high quality, operating conservatively with substantial safety margins in a circuit which includes multiple protective techniques to assure long, trouble-free operation. The transistors and integrated circuits have been selected for minimum noise and distortion in sustained use. Many close tolerance components, employed wherever warranted, assure continued adherence to the excellent specifications. The added ruggedness of all silicon transistors assures maximum reliability. The 3 factory-assembled epoxy-filled fiberglass circuit board modules in the kit, which contain all the semiconductors and active circuitry, are tested and critically adjusted for optimum performance under actual operating conditions before shipment. This assures that every unit can, with proper assembly, meet the specifications normally associated with laboratory prototypes. An entire power amplifier stage, including the output transistors, comprises one circuit board, so this complete section has in effect been factory tested in every kit.

The SCA-50 specifications speak for themselves, but specifications are unable to reveal all the facets contributing to exemplary sound quality. Separate regulated low voltage plus and minus power supplies for the preamplifier circuits assure freedom from AC line fluctuations or interaction with the power amplifier demands on high level passages. The output amplifier circuit is full complementary symmetry—

more likely seen in the most expensive designs, but rare in this power class. The bias supply thermally tracks the output transistors and thus “notch distortion” is avoided—often thought to be the source of “transistor sound” in otherwise technically competent designs showing very good specifications. Even the tone controls are unique. With the knowledge that the SCA-50 will frequently be selected by purists, a front panel switch *engages* the tone controls when desired, as they are normally out of the circuit. And, to make them more useful for most needs, their essential effect is limited to the extremes of the band, with a variable turnover characteristic in the bass.

This amplifier incorporates a number of protection techniques and circuits to guard against damage as a result of builder error or user abuse. Nonetheless, care in assembly and an understanding of the capabilities and the limits of so fine a piece of audio equipment is one of the best guarantees for continued satisfaction. Five fuses are employed—in the B+ and B- lines for each amplifier, and the AC line fuse for the entire unit. The failure of any of these should be cause for thorough investigation of the reason, especially if an identical replacement fuse also fails. Under no circumstances should you ever attempt to use a larger value fuse. Automatic current limiting protects the output devices without degrading the sound in the event of an output short or a load below 4 ohms until the B+ and B- fuses can blow. A thermal breaker will interrupt the program if excessive power demands cause appreciable temperature rise with potential damage to the outputs. It will automatically restore the signal after a cooldown period. Separate transient thump suppression circuits are incorporated in both power amplifier and preamplifier sections to minimize the possibility of turn-on and turn-off noises.

Proper interconnection and operation of your SCA-50 will assure your complete satisfaction. Therefore, read carefully the Operating Instructions next, and make all the connections to the audio inputs, and to the loudspeakers *before connecting the amplifier to the AC line.*

OPERATING INSTRUCTIONS

Connection to Loudspeakers

The *accuracy* and *security* of speaker connections is of significant importance in assuring trouble-free operation of a solid state amplifier. Please read this section through before turning the amplifier on, even though you may be familiar with most of it.

Two stereo pairs of loudspeakers may be connected to the SCA-50, speaker pair A, and speaker pair B. A symbol indicates the two adjacent terminals for each connection. The left channel is the top row of terminals. The black (common) terminals are internally connected, so you can use other equipment which requires common output grounds.

You must be certain that accessory equipment connections on the output never connect the + or live terminals together.

Likewise, *the amplifier must never be operated into a shorted speaker connection between the + and common terminals.*

Damage to the amplifier could result.

The A pair and B pair of speakers are selected by the front panel switches. Both may be operated at the same time, provided the load on the amplifier is 4 ohms or greater (parallel connection of two 8 ohm speakers), and so long as you do not try to operate the amplifier well beyond its capabilities, into “hard clipping” for any length of time.

If stranded wire, such as the popular lamp cord is used for speaker connections, the strands must first be twisted tightly together, or preferably “tinned” with solder to avoid fraying. It is *essential* that no wire strands can possibly touch the chassis, or another terminal at either the amplifier or the speaker.

Speakers may be either 8 or 16 ohm impedance. If 4 ohm speakers are used in one location, you should be careful not to play other speakers at the same time. Only one speaker system should be connected to each pair of terminals.

The power rating of the SCA-50 is based on a load impedance of 8 ohms. Into 16 ohms, solid state amplifiers deliver less power. As the load impedance is lowered, power output increases along with the heat, until either a protective circuit is actuated along with greatly increased distortion or shutdown, or a fault occurs. The actual impedance of most speakers is considerably less than their rated impedance at some frequencies—hence the importance of following the above paragraph, especially when playing at loud volume levels.

For speaker cables of less than 25 feet, ordinary #18 lamp cord is satisfactory. For longer distances, #16 lamp cord is suggested. Many speakers show slight sonic improvement with heavier gauge connecting cables, so it is wise to avoid the lighter wire often provided. The marking of speaker

terminals varies, but one terminal is usually identified as (+), (8 ohms), or in red. It is only important that the "sense" of the wiring to each speaker be consistent, so that all speakers will be connected *in phase*. Lamp cord invariably codes one lead—with a tracer thread wound around one wire, with a molded ridge on the outer plastic insulation, or with different color conductors.

Two speakers are connected in phase when maximum low frequency output is heard when they are driven from a *mono* source. Lowered output is the result when the connection to *one* of the speakers is reversed (out of phase, or reversed polarity). This is most apparent when the speakers are placed face to face about 6 inches apart for test purposes. No damage will result from improper phasing, but the sound quality will be impaired.

Phonograph Input Connection

The pair of input sockets marked *Phono* provide RIAA equalization for magnetic phonograph cartridges. The preamplifier stage has plenty of gain to accommodate all normal magnetic cartridges (nominal output 0.5 millivolt per centimeter per second, or greater) intended for the standard load impedance of 47,000 ohms. The reflected capacitance at the input is 10 picofarads. The upper row of input connections is intended for the left channel.

Ground Connection

Some phonograph cables include an extra wire which is to be attached to the amplifier chassis. The screw marked GND is provided for this purpose. Under some unusual conditions of use, where it is advisable to ground the system to an earth ground, such as a water pipe, this screw can serve as the connection point.

In general, it is advisable to use the *minimum* number of separate ground leads necessary to achieve lowest hum. Some experimentation may be necessary, but extra leads often cause an increase in the hum level of the system.

Tuner and Spare Connection

These identical high level inputs accept flat signals of ½ volt or more from AM and FM Multiplex tuners, the audio signal from a television set, or a third tape recorder.

Connection from Tape Recorders

Inputs are provided for playback from two tape recorders, identified as *Tape 1* and *Tape 2*. These are similar to the *Tuner* and *Spare* inputs, with the exception that monitoring access is also provided on the *Tape 1* input. This feature, applicable to recorders having independent heads and electronics for record and playback, is explained later in connection with the Monitor Switch.

Cables from the "preamp output" or "line output" of the recorder connect to these Tape inputs, and for normal playback, are selected by the Selector Switch. The Monitor Switch will also select the *Tape 1* input, as described later.

Do not operate a tape recorder in the fast wind or rewind mode when the volume control is advanced, as this could produce large signals at inaudible frequencies, with consequent risk to your amplifier and speakers.

Tape "decks", which do not contain playback electronics, but supply only a very low level signal directly from the playback head, are not intended for use with equipment like the SCA-50.

Connection to Tape Recorders

For direct recording of an input to the amplifier, such as a record or radio program, audio cables connect from the *Tape Out* jacks on the SCA-50 to the "radio", "high level" or "line" inputs on the recorder. These inputs should have a nominal sensitivity between 100 millivolts and one volt. Microphone inputs have too high a sensitivity (a few millivolts) and are not suitable.

The output from *Tape Out 1* is paralleled with *Tape Out 2*. The combined load impedance on these two outputs should be more than 10,000 ohms. In other words, if two recorders are connected, each should have an input impedance of at least 20,000 ohms. These tape outputs are ahead of the Mono switch in the SCA-50, as well as all other controls except the Selector Switch and Monitor Switch, so tape out signals are always stereo. If an external Y adapter is used to obtain a mono recording, it will have the same effect on the speaker outputs as switching the amplifier to mono. The amplifier controls can adjust the speaker signals at will, without affecting signals to the recorder.

Selector Switch

This selects the program source in both channels simultaneously. Unlike some other amplifiers, even routine playback from a tape recorder is selected here, to avoid confusion. The tape Monitor Switch must be "out" for selector functioning.

Volume Control

The output level of both channels is adjusted simultaneously by this control, with close tracking so that the program material will remain in balance over most of its range. The control taper provides a relatively slow increase in volume over the first half of rotation, with a more rapid increase above 12 o'clock. This helps to accommodate both high and low output phono cartridges, as well as speakers of differing efficiencies.

The particular setting of the volume control in no way indicates relative power outputs, either between units, or as a percentage of maximum output capability. The design of the control, the input level and the speaker efficiency are of far greater significance in such comparisons.

Balance Control

This control will normally be centered for equal signals in the two channels. Rotation to the right reduces the left channel level, shifting the apparent source to the right, and conversely. This control has a very gradual change for the first 90° either side of center to facilitate subtle adjustments, but one channel is silenced at either extreme of rotation.

Adjustment for proper balance may be necessary because of differing speaker efficiencies or inequities in energy distribution from speaker placement or furnishings, as well as occasional program variations. You may wish to re-position the knob so it is centered, correcting for an essentially "permanent" difference in normal listening.

Tone Controls

The normal or "flat" position is centered, with increasing effect to the right, and reduction to the left. Tone controls alter the signal to suit the user; such deviations from the assumed accuracy of the original should be undertaken with care, and the reference point should always be the center. However, particular effort was expended in the design to make these controls musically useful, to help correct for room and speaker deficiencies, or program limitations.

The tone controls are engaged only when the Tone Controls switch is *in*. Audio purists frequently prefer a flat output, and the quality of the SCA-50 is of such high order that it will often be chosen by such critical listeners.

Initially these controls may seem less effective than some others, because they have been deliberately designed to have very little effect on the midrange, even though substantial alteration of the extremes is possible. This superior design assures that the critical voice range is essentially unaltered until the controls are rotated close to their limits.

Monitor Switch

This switch, on the *Tape 1* input, enables direct comparison of the source indicated by the Selector Switch (button normally *out*) with the signal from the playback amplifier of the tape recorder (button *in*). This is realizable only with tape recorders which have independent heads and electronics for record and playback—common on reel to reel machines, but available on only a few expensive cassette models. This switching does not interfere with the normal recording process—that signal as indicated by the Selector Switch continues unaltered. When the button is depressed, you will hear the program from the tape a fraction of a second after it has been recorded (the time interval is determined by the head spacing and tape speed). The recorder's own monitor switch must remain in the *tape, compare, playback* or *monitor* position.

Remember to keep the Monitor Switch *out* normally, or you will get no signal from any of the other program sources selected by the Selector Switch. The Monitor Switch does nothing when the Selector Switch is in the *Tape 1* position.

Mono Switch

The normal *out* position is for stereo listening with maximum separation. When pushed *in*, the two channel signals are paralleled, and the combined signal is heard through both speakers, unless the Balance Control is turned to one extreme. This is the proper position for listening to monophonic records played by a stereo cartridge, as it eliminates the vertical noise components of the signal. When listening to a monophonic radio broadcast with some tuners, too, or when listening to a very weak stereo signal, some improvement may be noted in the mono position. If a monophonic

source, such as TV sound, is connected to one channel input, this signal will be heard through both speakers when this switch is in the mono position. If two different mono sources are connected to the left and right Spare inputs, for instance, they will be mixed in proportion to their relative levels unless the unwanted one is switched off at the source.

Loudness Switch

This provides automatic bass boost in the lower half of volume control rotation to compensate for the ear's lack of sensitivity to low frequencies at low sound levels. The high fidelity purist often avoids such compensation, but many listeners will find it adds listening enjoyment at low levels.

Tone Controls Switch

To actuate tonal correction with the Bass and Treble Controls, this switch must be *in*.

Speakers Switches

Speaker pairs A (main) or B (remote) are connected when these switches are *in*. No speakers are connected when both switches are *out*.

Headphone Jack

A standard 3-circuit phone plug fits this output, wired so that the tip connection is the left channel. Series resistors attenuate the amplifier output, and headphones of 4 ohms or higher impedance may be used. Usually, you would disconnect the speakers (buttons *out*) when headphones are used, so you must be careful that the phones are not damaged by excessive signal when they are plugged in, but not in use. It is advisable to switch on one set of speakers when the headphones are unplugged, so you are aware the amplifier is operating.

Power Switch

This switch also operates the two AC outlets on the back panel identified as "switched", turning them on and off with the amplifier. It is recommended that mechanical units, such as record players and tape recorders, be connected to *unswitched* outlets. Their drive mechanisms cannot then be damaged if the power is turned off without disengaging the machine.

INSTALLATION INSTRUCTIONS

The SCA-50 amplifier generates some heat in normal use, so adequate ventilation must be provided to assure long, trouble-free life. As with all transistorized amplifiers, heat output increases with higher power demands, up to a maximum at about half the power rating. Also, the lower the load impedance, the greater the heat, so operating two sets of speakers will cause the amplifier to run warmer.

You must never limit the air flow through and around the SCA-50. **Do not set anything on top of the cover.** Vertical (face up) mounting is not encouraged, since the heat dissipation is not as effective as in the normal horizontal placement for which the amplifier was intended. If the unit *must* be mounted face up, a fan is recommended to circulate the air around the heat sink fins.

If the amplifier remains on without signal input for an extended period of time, no problems will be encountered, for the transistors remain relatively cool except under high signal conditions. With sustained high power output, it is normal for the bottom plate to get much warmer than the cover, for the heat sinks dissipate heat to the chassis. At full (or half) power, the SCA-50 puts out as much heat as a 200 watt light bulb—just as much heat as an equivalently

powered tube amplifier. Excessive temperature rise will automatically shut off the amplifier, and it will turn on again after the heat sinks and chassis have cooled down.

Panel mounting requires a single rectangular cutout 13-1/16" by 3-15/16". The rubber feet are removed for such installations. You can simply provide a shelf flush with the bottom of the opening. Be sure to cut out the shelf in the area of the ventilation perforations in the chassis. If you wish to stack the SCA-50 with a Dynaco tuner, the amplifier *must be mounted on top* for adequate ventilation. If the tuner is shorter, like the FM-5, the rear feet may be moved forward for support.

For single unit panel installations, you can avoid the need for the supporting shelf if you have access from the rear, with the accessory PBK bracket kit. It can accommodate panels up to 1" thick. The PBK kit is available only direct from Dynaco for \$3.50 postpaid (no CODs, please).

Oiled walnut veneer cabinets are available from your dealer to handsomely set off your Dynaco components. Either single or double stacked versions are provided at modest cost.

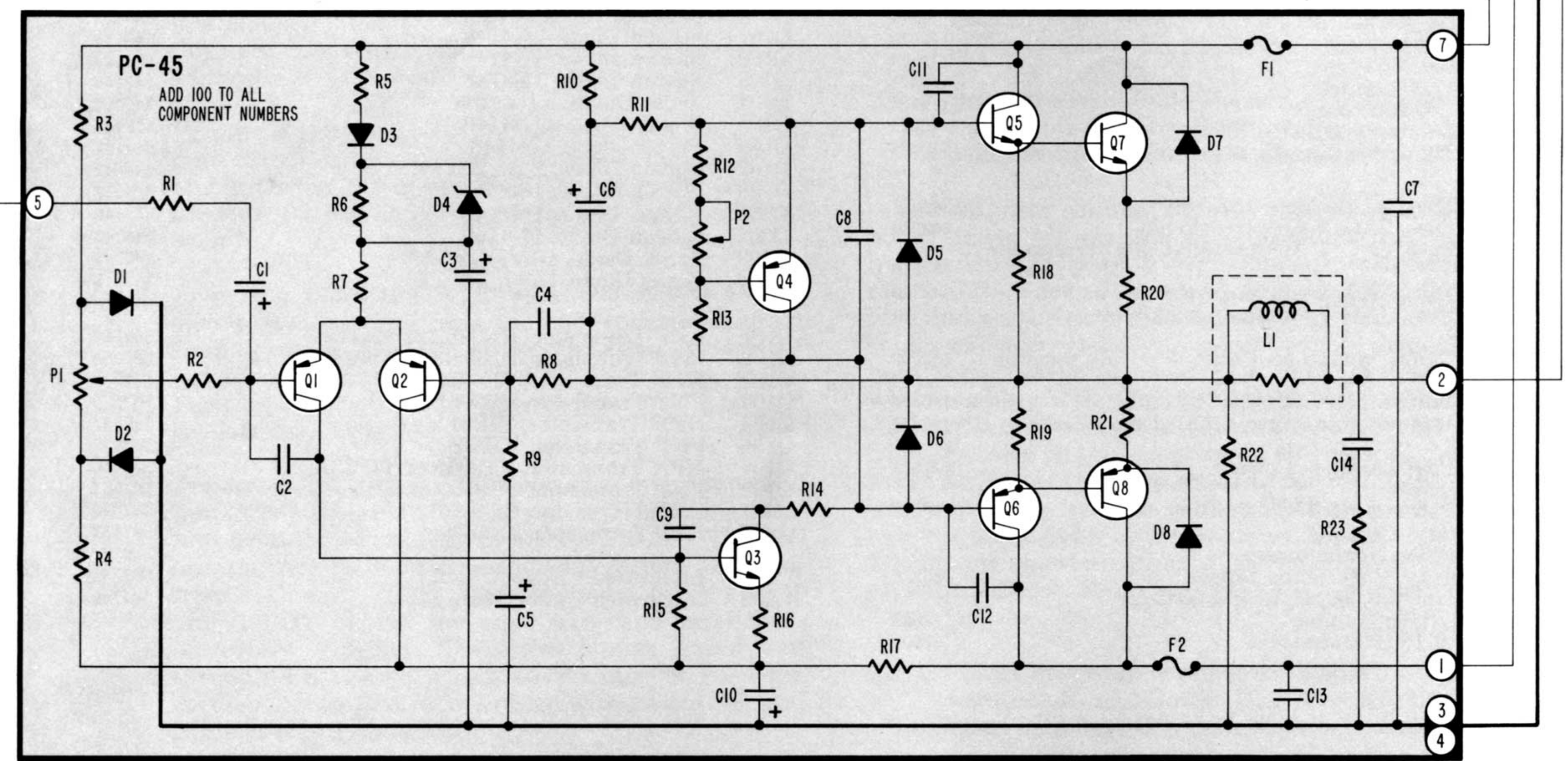
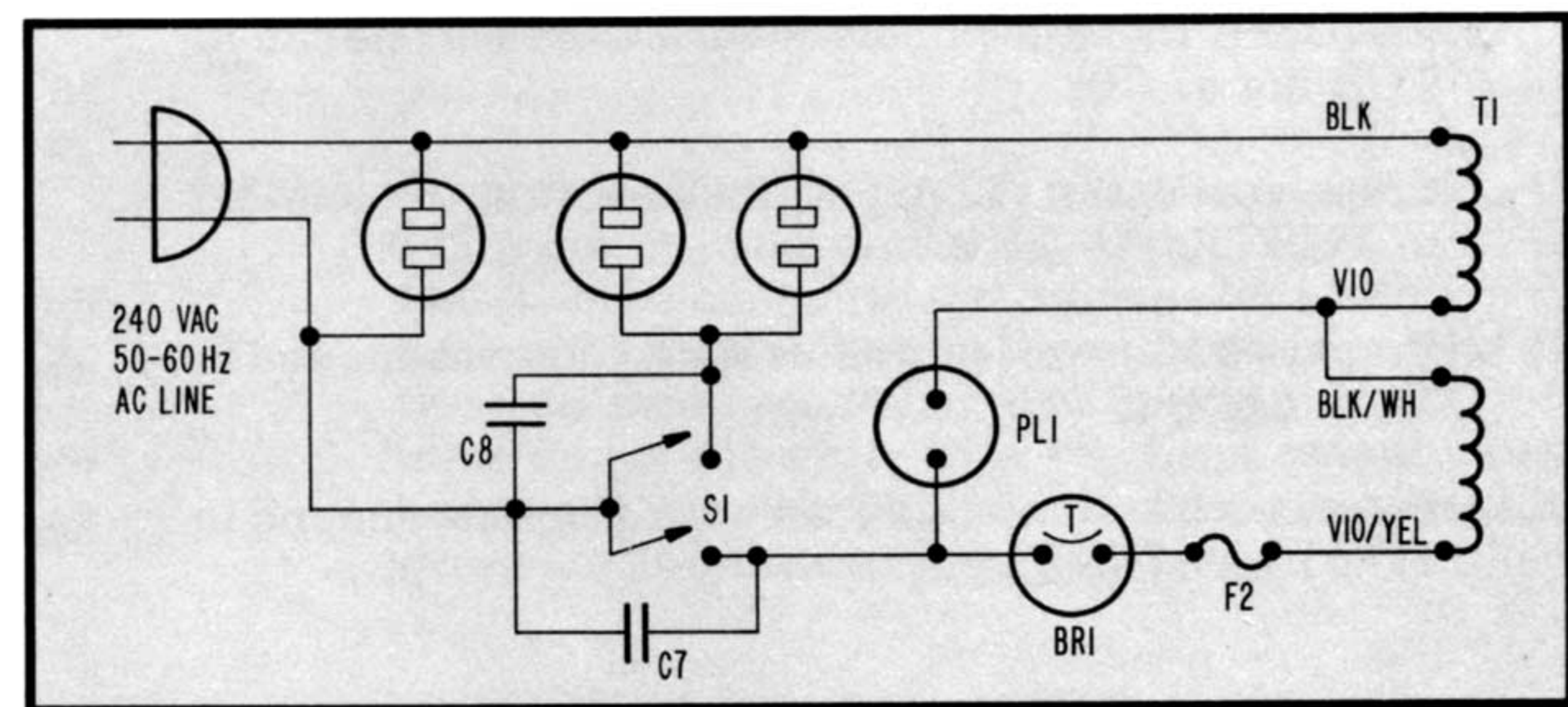
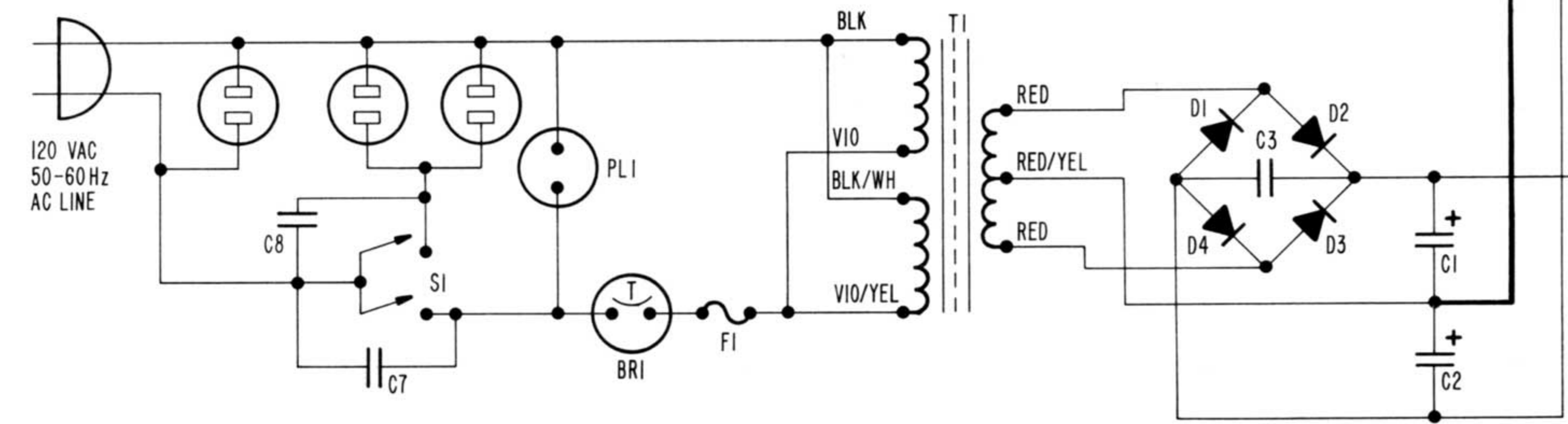


□ LEFT CHANNEL
○ RIGHT CHANNEL

ONLY LEFT CHANNEL IS SHOWN WHERE RIGHT CHANNEL IS IDENTICAL.

PUSH BUTTON SWITCHES SHOWN IN OUT POSITION.

COMPONENT VALUES

PART NO.

All resistors are 1/4 watt, 5% unless otherwise indicated.

<p>R 1 1,000 ohms R 2 1,000 ohms R 3 8,200 ohms R 4 100 ohms, 1 watt, 5% R101 1,000 ohms R102 24,000 ohms R103 24,000 ohms R104 24,000 ohms R105 10 ohms R106 1,800 ohms R107 10,000 ohms R108 24,000 ohms R109 1,800 ohms R110 1,800 ohms R111 2,200 ohms R112 10,000 ohms R113 20,000 ohms R114 47 ohms R115 1,000 ohms R116 22 ohms R117 100 ohms R118 100 ohms R119 100 ohms R120 0.3 ohm, 2 watts, 5% wire wound R121 0.3 ohm, 2 watts, 5% wire wound R122 1,000 ohms, 1/2 watt, 5% R123 10 ohms, 1/2 watt, 5% R201 360 ohms R202 470 ohms R203 100,000 ohms R204 100,000 ohms R205 470 ohms R206 22,000 ohms R207 330,000 ohms R208 560 ohms R209 1,000 ohms R210 220,000 ohms R211 1,000,000 ohms R212 10,000 ohms R213 10,000 ohms R214 4,700 ohms R215 1,000 ohms R216 1,000 ohms R217 1,000,000 ohms R218 150 ohms R219 4,700 ohms R220 750 ohms R221 2,000,000 ohms R222 150,000 ohms R223 100,000 ohms R224 270,000 ohms R225 47,000 ohms R226 100,000 ohms R227 47,000 ohms R228 1,000,000 ohms R229 270 ohms, 2 watts, 5% R230 270 ohms, 2 watts, 5%</p> <p>BR 1 Thermal Breaker, 15A., 80°C. F 1 Fuse, 3AG, 2 Ampere, slo-blo F 2 Fuse, 3AG, 1 Ampere, slo-blo (alternate for 240 v. use) F101 Fuse, 3AG, 2 Ampere, quick blow F102 Fuse, 3AG, 2 Ampere, quick blow</p> <p>L101 Choke, wound on 1 ohm, 5 w., 5%, resistor</p> <p>P101 Trimpot, miniature, 4,700 ohms P102 Trimpot, miniature, 4,700 ohms</p> <p>PL 1 Pilot Lamp, red neon</p> <p>S 1 Power Switch, TV-5 rating</p> <p>T 1 Power Transformer</p> <p>Volume Control, 100,000 ohms, tapped Balance Control, 100,000 ohms, special taper Bass Control, 100,000 ohms Treble Control, 100,000 ohms</p>	<p>PART NO.</p>	<p>C 1 4,700 (or 5,000) mfd, 35 v., electrolytic C 2 4,700 (or 5,000) mfd, 35 v., electrolytic C 3 .01 mfd, 500 v., 20%, disc C 4 .01 mfd, 100 v., 20%, disc C 5 .056 mfd, 250 v., 5%, polyester C 6 68 pf, 500 v., 10%, disc C 7 .01 mfd, 500 v., 20%, disc C 8 .01 mfd, 500 v., 20%, disc C101 4.7 (or 5) mfd, 15 v., 20%, tantalum C102 150 pf, 500 v., 10%, disc C103 250 mfd, 35 v., electrolytic C104 56 pf, 500 v., 10%, disc C105 47 (or 50) mfd, 25 v., electrolytic C106 47 (or 50) mfd, 25 v., electrolytic C107 0.1 mfd, 100 v., 20%, disc C108 0.1 mfd, 100 v., 20%, disc C109 22 pf, 100 v., 10%, disc C110 47 (or 50) mfd, 35 v., electrolytic C111 500 pf, 100 v., 10%, disc C112 500 pf, 100 v., 10%, disc C113 0.1 mfd, 100 v., 20%, disc C114 0.1 mfd, 100 v., 20%, disc C201 47 (or 50) mfd, 10 v., NP electrolytic C202 4.7 (or 5) mfd, 15 v., NP electrolytic C203 .01 mfd, 100 v., 20%, disc C204 .01 mfd, 100 v., 20%, disc C205 12 pf, 500 v., 5%, disc C206 82 pf, 100 v., 10%, disc C207 .0033 mfd, 100 v., 5%, polyester C208 .012 mfd, 100 v., 5%, polyester C209 4.7 (or 5) mfd, 15 v., NP electrolytic C210 500 pf, 500 v., 10%, disc C211 .22 mfd, 100 v., 10%, polyester C212 5.6 pf, 500 v., 10%, NPO disc C213 1800 pf, 100 v., 10%, disc C214 12 pf, 500 v., 5%, disc C215 4.7 (or 5) mfd, 15 v., NP electrolytic C216 4.7 (or 5) mfd, 15 v., NP electrolytic C217 .033 mfd, 100 v., 5%, polyester C218 .33 mfd, 100 v., 5%, polyester C219 .001 mfd, 100 v., 5%, polyester C220 .01 mfd, 100 v., 5%, polyester C221 .01 mfd, 100 v., 20%, disc C222 .01 mfd, 100 v., 20%, disc C223 47 (or 50) mfd, 25 v., electrolytic C224 47 (or 50) mfd, 25 v., electrolytic C225 100 mfd, 15 v., electrolytic C226 100 mfd, 15 v., electrolytic</p> <p>D 1 Rectifier Diode, 3 A., 200 PRV D 2 Rectifier Diode, 3 A., 200 PRV D 3 Rectifier Diode, 3 A., 200 PRV D 4 Rectifier Diode, 3 A., 200 PRV D101 Silicon Diode, 1N4148 D102 Silicon Diode, 1N4148 D103 Silicon Diode, 1N4148 D104 Zener Diode, 5.1 v., 5% D105 Silicon Diode, 1N4148 D106 Silicon Diode, 1N4148 D107 Silicon Diode, 1 A., 200 PRV D108 Silicon Diode, 1A., 200 PRV D201 Silicon Diode, 1N4148 D202 Silicon Diode, 1N4148 D203 Zener Diode, 15 v., 1 w., 5% D204 Zener Diode, 15 v., 1 w., 5%</p> <p>Q101 PNP Transistor, EN3962 or PN4249 Q102 PNP Transistor, EN3962 or PN4249 Q103 NPN Transistor, SE6020 Q104 PNP Transistor, BC308B Q105 NPN Transistor, TIP31 Q106 PNP Transistor, TIP32 Q107 NPN Transistor, FT3055 or TIP33A Q108 NPN Transistor, FT2955 or TIP34A Q201 PNP Transistor, BC308B Q202 FET Transistor, 2N5638</p> <p>IC201 Integrated Circuit, TBA231 IC202 Integrated Circuit, TBA231</p>	<p>238478 238478 228103 234103 265563 237680 228103 228103 282505 238151 283247 234560 282500 282500 224104 224104 234220 283476 245501 245501 224104 224104 282506 281504 234103 234103 244120 224820 264342 264123 281504 245501 204224 244050 244182 244120 281504 281504 264335 260334 264102 264013 234103 234103 282500 282500 281101 281101</p> <p>544322 544322 544322 544322 543148 543148 543148 540405 543148 543148 544012 544012 543148 543148 540115 540115</p> <p>562962 562962 577021 567070 577031 567032 571846 562963 567070 597463</p> <p>587739 587739</p>
--	-----------------	---	---

VOLTAGES

All voltages on PC-45 are based on a 120 volts, 60 Hz AC line. All voltages on PC-46 should be stable with incoming AC line variations from 100 to 130 volts, 60 Hz, unless indicated otherwise. All voltages are nominal $\pm 20\%$ unless specified. Condition of test: shorted input. NOTE: 0 means less than ± 25 millivolts.

PC-45 Amplifiers

SEMI-CONDUCTOR	DC VOLTAGE	SEMI-CONDUCTOR	DC VOLTAGE
Q101		Q105	
E	+0.8	E	+0.55
B	+0.15	B	+1.1
C	-28	C	+30
Q102		Q106	
E	+0.8	E	-0.55
B	+0.15	B	-1.1
C	-29	C	-30
Q103		Q107	
E	-28.5	E	0
B	-28	B	+0.55
C	-0.15	C	+30
Q104		Q108	
E	+1.1	E	0
B	+0.5	B	-0.55
C	-1.1	C	-30

POWER SUPPLY
 B+: +30, ± 2
 B- : -30, ± 2

Transformer Red Leads:
 22 VAC, ± 2 , to Ground

PC-46 Preamplifier

SEMI-CONDUCTOR	DC VOLTAGE	SEMI-CONDUCTOR	DC VOLTAGE
IC201		IC202	
1	± 1	1	± 1
2	+14	2	+14
3	+11.5	3	+11.5
4	+11.5	4	+11.5
5	< -2	5	< -0.2
6	< -2	6	< -0.2
7	-15	7	-15
8	< -2	8	< -0.2
9	< -2	9	< -0.2
10	+11.5	10	+11.5
11	+11.5	11	+11.5
12	+14	12	+14
13	± 1	13	± 1
14	+15	14	+15
SEMI-CONDUCTOR	DC VOLTAGE	SEMI-CONDUCTOR	DC VOLTAGE
Q201		Q202	
E	0	G	-15
B	+0.2	D	0
C	-15	S	0

NOTE: When measuring voltages, it is important to take volt meter accuracy into account. Most volt meters are specified for accuracy with respect to the range selected. This means, for example, that a voltage reading on $\pm 5\%$ meter could be off by ± 5 volts on the 100 volt range. In the SCA-50 this could imply an incorrect indication when measuring the DC supply, which has been specified ± 2 volts (with a 120 volt line). If the voltages were 30 volts ± 2 volts, a $\pm 5\%$ meter reading could indicate a voltage from 26 to 34 and still be within the specifications of both the meter tolerance and the voltage tolerance. It is therefore necessary to always consider the tolerance of *both* the voltage being measured and of the measuring instrument.

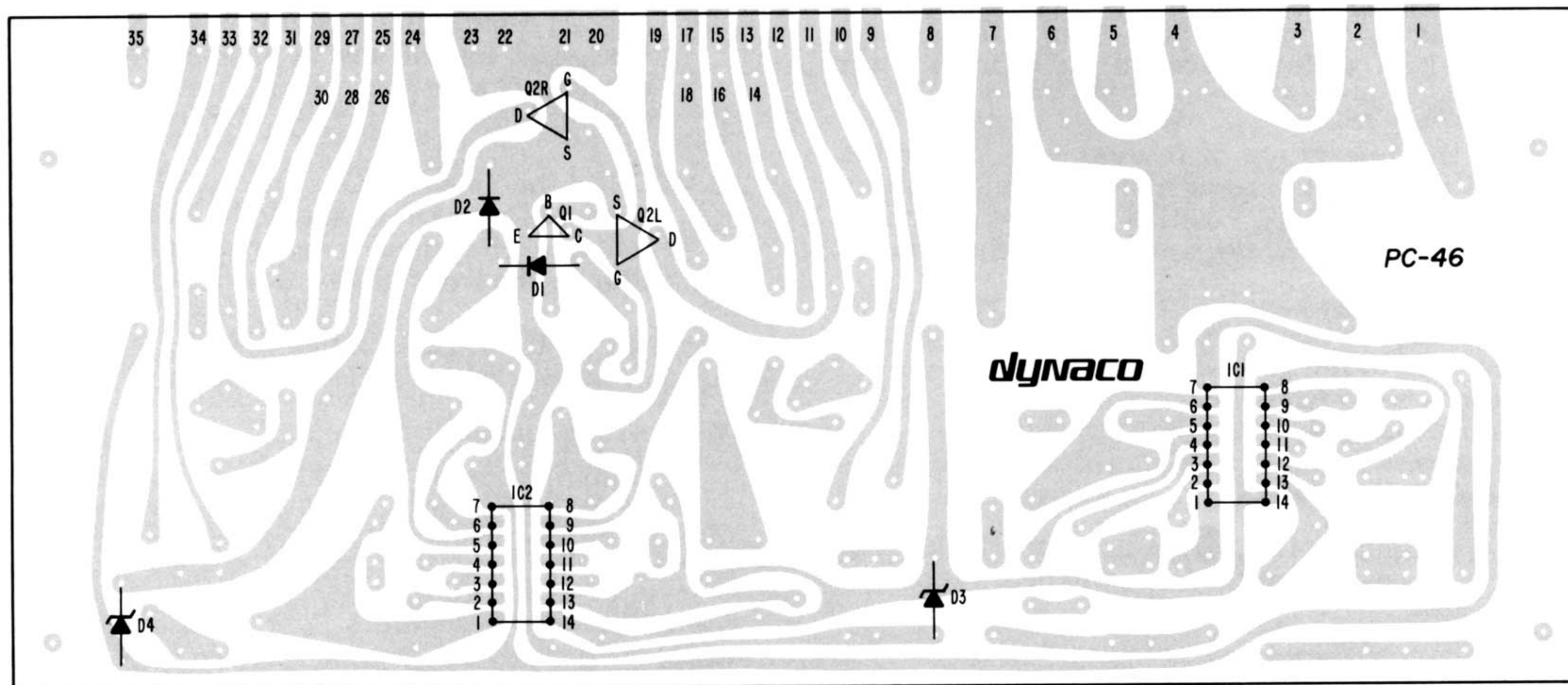
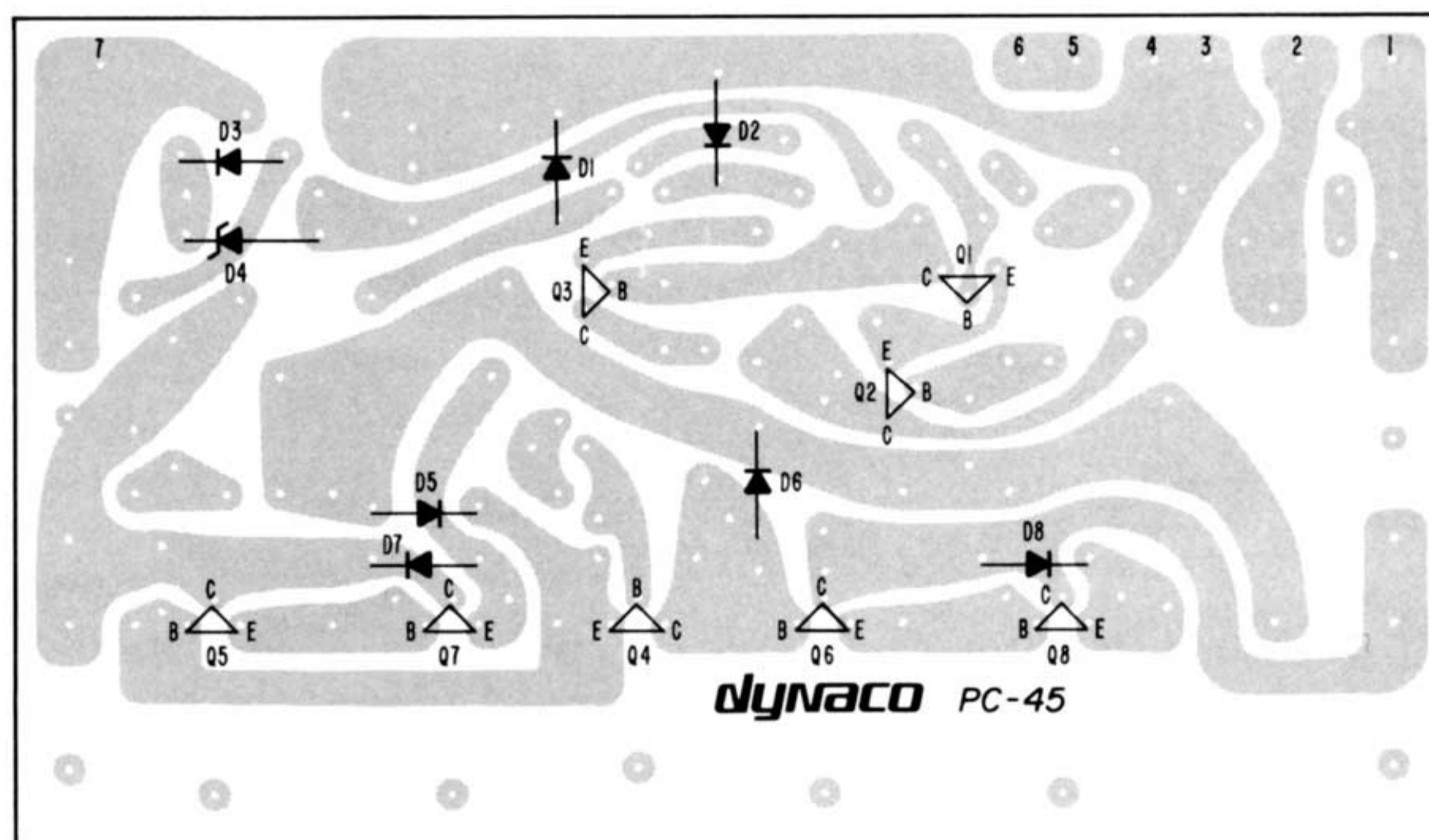

IN CASE OF DIFFICULTY

If there is an initial fault with your component system, or one develops in use, separate units enable relatively easy diagnosis of the problem. Before blaming electronics, check the connections on all components, particularly carefully on the SCA-50. See that all the connections agree with the OPERATING INSTRUCTIONS. See that the Power Switch is *in*, check to see that the Monitor Switch is in its normally *out* position, and observe that the Speaker Switch "A" is pushed *in* (assuming that your "main" speakers are connected to the "A" terminals on the back of the amplifier).

If neither channel works with any program source (phono, tuner, and tape), it is unlikely that all sources would be faulty. Either the system is incorrectly connected, or the SCA-50 is likely the cause of the problem.

A fault in only one channel suggests interchanging the audio cables channel for channel to determine the source of the problem. If the problem occurs with only one sound source, such as phonograph, interchange its cables at the SCA-50. Check the phono cables, the connection of the cartridge in its mounting shell, and the connecting pins between the shell and the tone arm. These are all more likely problem areas than the cartridge itself. Next check with a tuner or tape deck by interchanging its cables at the SCA-50. Once again, if the problem reverses channels, the fault lies in the source or its cables. If the fault remains in the same channel, the source is all right. Finally check the speaker wires and the speakers. If the fault lies in one channel with any sound source, regardless of the location of the speakers or speaker wires, one channel of the SCA-50 is faulty.

Because 90% of the difficulties encountered with kit-built units can be attributed to incorrect wiring or poor solder connections, it is strongly recommended that you ask someone else to check your wiring against the Pictorial Diagram, for one person will frequently make the same error repeatedly.

There are certain general precautions to be observed when servicing any semiconductor equipment:

1. Never make circuit changes of any kind when the amplifier is turned on.
2. Be particularly careful not to short any semiconductor leads to each other or to the chassis when the power is on.
3. When using test equipment, you must avoid transient voltage peaks and excessive test voltages.
4. Exercise caution when soldering and unsoldering semiconductor leads to avoid excessive heat.

If circuit difficulties are encountered with the SCA-50, the average kit builder will not likely be able to locate the source of the problem. **DO NOT ATTEMPT TO SERVICE THIS AMPLIFIER UNLESS YOU HAVE THE KNOW-HOW AND SUITABLE TEST EQUIPMENT.**

CHECKING SEMICONDUCTORS

An ohmmeter can sometimes serve as a gross check for transistor or diode failure. The device must be removed from the circuit. Diodes should have a high resistance in one direction (probe polarity) and a low resistance in the other.

Transistor types vary widely in resistance, but a (near) short circuit indicates probable failure. Readings from base to collector should be similar to those from base to emitter. Both will have a higher reading with one probe polarity than with the reverse orientation. NOTE: Some types of solid state meters do not provide enough probe voltage to forward bias a silicon junction. Hence, a high resistance reading may be obtained on both directions.

Such gross checks can only ascertain clearly faulty semiconductors. More sophisticated test equipment, or direct substitution is necessary to qualitatively evaluate their performance.

PROBLEM	TEST POINTS	PROCEDURE FOR FINDING THE MOST PROBABLE CAUSE OF FAILURE
No output on one or both channels	PC-45 F101, F102	Check the B+ and B- fuses; if fuses are blown, check Q107 and Q108; replace fuses
	PC-45 Hole #5	If fuses are good, apply a signal to tuner input and see if it is present at input to PC-45; if there is no signal at PC-45, check PC-46.
No output from PC-46	PC-46 D203 Cathode D204 Anode	Check for regulated B+ and B- on PC-46; if voltage is not $\approx 15V$, check D203, D204, C225, C226.
	IC-202 LEFT CHANNEL Input—Pin 9 Output—Pin 13 RIGHT CHANNEL Input—Pin 5 Output—Pin 1	If + and - 15 volts is present, check to see if input signal is present on IC-202. If an input signal is present but no output signal appears, replace IC-202.
Very low output in all modes	PC-46 thump suppression circuit	Check Q201, Q202, Q203.
No output from phono	IC-201 LEFT CHANNEL Input—Pin 9 Output—Pin 13 RIGHT CHANNEL Input—Pin 5 Output—Pin 1	If + and - 15 volts is present, apply signal to phono input, and check for input and output signal on IC-201. If no output signal appears, replace IC-201.

CHART NOTE:

Chart indicates possible defective semiconductors, but associated components should also be investigated.

BIAS ADJUSTMENT

The output bias current has been set at the factory, and should remain in proper adjustment for the life of the amplifier. However, should you wish to check the output bias, the following procedure should be followed:

1. Remove the input connections, and also the load from the output connections.
2. Remove the B+ fuse (F101 on PC-45) from the channel to be adjusted (you should not remove the B- fuse).
3. Connect the "+" lead of an ammeter to the upper fuse clip, and the ground lead to the lower fuse clip. Avoid shorting out the leads or allowing them to make intermittent connections.
4. Turn on the unit, wait about 10 seconds, and adjust the B+ current (trimpot P102) for approximately 45 milliamps.
5. Leave the amplifier on for 10 minutes until operating temperatures have stabilized. With a volt meter connected to the output terminals, set the center line voltage (trimpot P101) for 0 volts (± 20 millivolts).
6. Once again check the B+ current. It should still be about 45 milliamps. If not, readjust to that value.

Repeat the procedure for the other channel. Since the amplifier's temperature will have been stabilized, wait only 2-5 minutes before adjusting the center line and finally rechecking the B+ current.

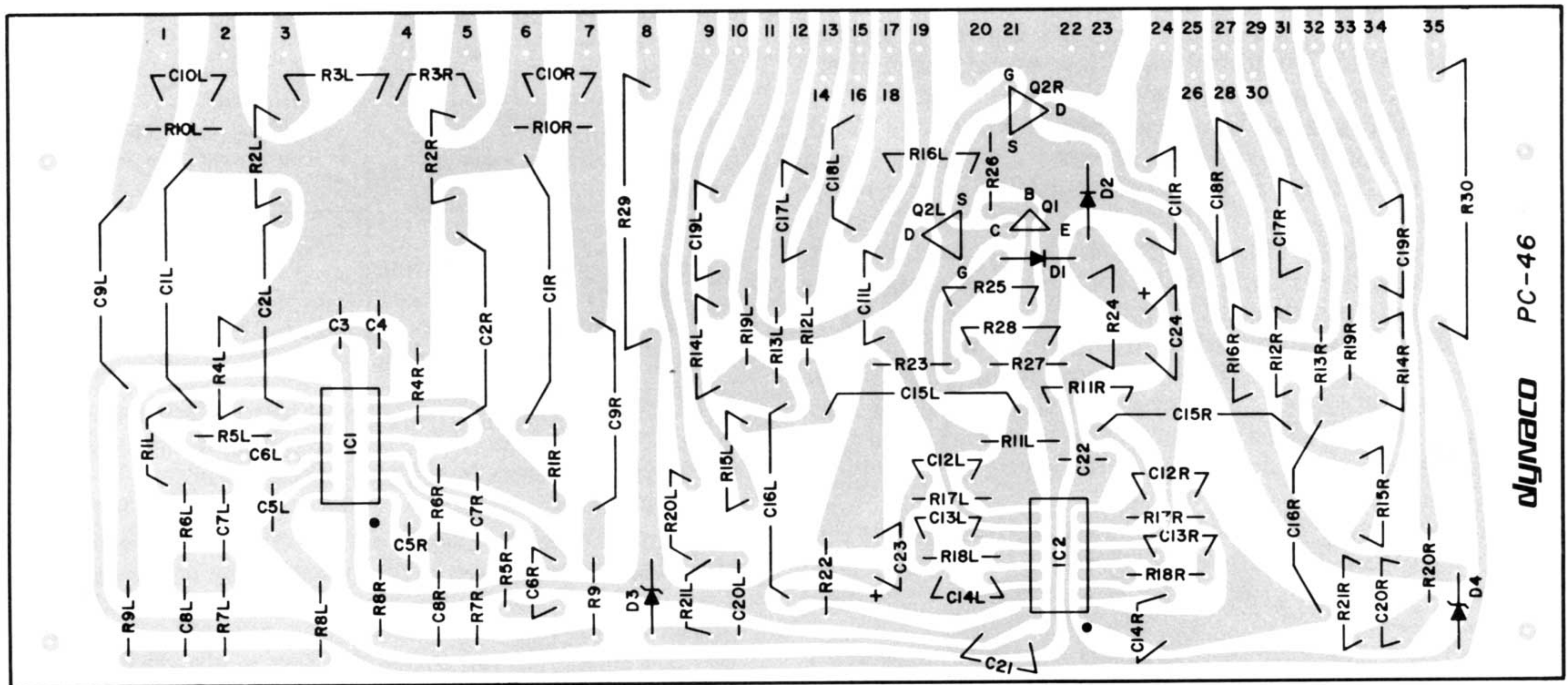
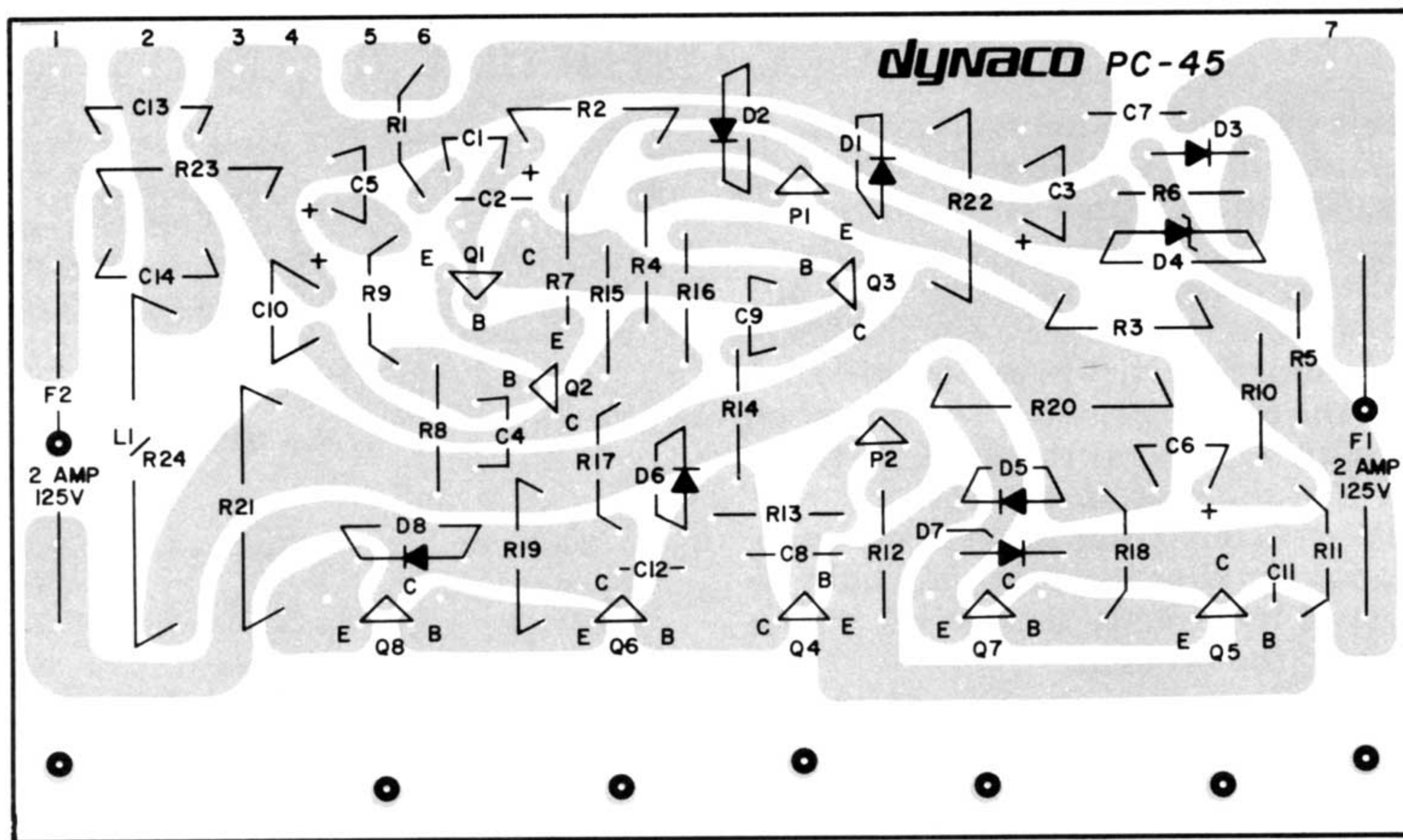

SERVICE POLICY AND LIMITED WARRANTY

The SCA-50 has been carefully engineered to provide many years of musical enjoyment without difficulty. Each factory-assembled SCA-50 has been subjected to a full complement of performance tests prior to shipment. Nevertheless, through damage in transit, faulty kit assembly, or human error, service may sometimes be required.

To provide rapid and reliable service, Dynaco has authorized competent, well-equipped service facilities in several localities in the United States and Canada, in addition to its service facility at the factory. These stations are authorized to make repairs in and out of warranty under the terms listed below. Service is always available at the factory, but you will often find a more convenient facility locally. A current list of these facilities is enclosed. Write to Dynaco for the name of the service station nearest you.

It is the owner's responsibility to *take or send the unit freight prepaid to the service facility. A dated bill of sale must be submitted.* In the event that you incorrectly diagnose which unit is faulty, please understand that you will be responsible for a check-out charge on any properly performing kit or factory-assembled unit submitted for testing.

Shipment should be made via United Parcel Service (Express in Canada), whenever possible. **DO NOT USE PARCEL POST FOR IT IS NOT A SAFE METHOD OF SHIPPING ELECTRONIC EQUIPMENT.** Should damage occur because of parcel post shipment, repairs will be made at the owner's expense, as neither the factory nor the service stations has the facilities to process parcel post claims. Insure the carton for the full value of a *factory wired* SCA-50.

When shipping the amplifier, use the original carton with all the styrofoam inserts and plastic bag. Include with the returned unit the following information:

1. Your name and complete shipping address (Post Office box numbers are not suitable);
2. The serial number (from the cover of this manual), *together with a copy of your dated bill of sale;*
3. The symptoms, complete, but preferably brief. If the problem is intermittent, this *must* be noted.

Once service work has been performed, an additional 90 day warranty on the service work is provided.

PARTS LIST

Parts of a similar type which do not change performance will sometimes be included as a matter of expediency. This will account for slight variations in value and appearance. To avoid a shortage, extra hardware may be included for some sizes.

	PART #		
1 Chassis, black, steel	711060		
1 Back Panel, black, steel	711061		
1 Cover, black, steel	711021		
1 Front Plate, decorative, aluminum	769052		
2 Circuit Board Assembly, amplifier, PC-45	957045		
1 Circuit Board Assembly, preamplifier, PC-46	957046		
1 Transformer, power, dual voltage	464027		
3 AC outlet, black 351001			
2 Bracket, capacitor, round	717001		
2 Bracket, PC-46, "L" shape	710422		
1 Breaker, thermal	342017		
2 Capacitor, electrolytic, 4700 or 5000 mfd	283478		
1 Control, balance	167755		
2 Control, bass and treble	167505		
1 Control, volume	160225		
1 Fuse Holder	341003		
2 Heat Sink Fin, PC-45	766014		
1 Jack, headphone	355013		
2 Knob, large, aluminum, with indent	764188		
3 Knob, small, aluminum, with indent	764187		
7 Knob, push button switch, aluminum	814053		
1 Label, serial number	898011		
1 Label, caution, fuse replacement (Canada only)	898019		
1 Label, caution, speaker (Canada only)	898027		
1 Lamp, pilot, red neon	521022		
1 Line Cord	322092		
2 Socket Strip, 3-input	355003		
2 Socket Strip, 4-input	355004		
1 Switch, power, single-position, button	338007		
1 Switch, 6-position, button	338008		
1 Switch, selector, rotary	333170		
1 Terminal Strip, 2-lug	372001		
1 Terminal Strip, 6-lug	375010		
2 Terminal Strip, 4-screw	374005		
1 Thermal Compound, capsule	945004		
5 Wire Tie	894003		
1 Wire, #20 hookup, black, 15.5 ft.			
1 Wire, #20 hookup, white, 9 ft.			
1 Wire, #20 hookup, red, 13.5 ft.			
1 Wire, #20 hookup, green, 11 ft.			
1 Wire, #20 hookup, yellow, 8 ft.			
1 Wire, #20 hookup, blue, 10 ft.			
1 Wire, #16 hookup, orange, 5 ft.			
1 Warranty Card			
1 Manual, instruction			
<i>Resistor-Capacitor Assembly</i> 997187			
		3 Capacitor, .01 mfd, 500 (or 1,000) v., disc (large)	228103
		2 Capacitor, .01 mfd, 100 v., disc (small)	234103
		2 Capacitor, 68 pf disc	237680
		2 Capacitor, .056 mfd, axial lead	265563
		4 Diode, 3A, 200 PRV	544322
		1 Fuse, 2 Ampere Slo-Blo	342020
		1 Fuse, 1 Ampere Slo-Blo (alternate for 240 v. only)	342010
		2 Resistor, 100 ohm, 1 w., 5% (brown-black-brown)	116101
		2 Resistor, 1000 ohm, 1/4 w., 5% (brown-black-red)	119102
		2 Resistor, 8200 ohm, 1/4 w., 5% (gray-red-red)	119822
<i>Foot-Thumb Screw Assembly</i> 997188			
		4 Foot, rubber	859001
		4 Thumb Screw, brass color	623361
		4 Thumb Screw, black color	623367
		1 Strain Relief	895001
		1 Wrench, Allen set screw, 5-40	968522
		1 Insulating Strip, 5"	854001
<i>#1 Hardware Assembly</i> 997189			
		42 #4-40 x 5/16" machine screw	611254
		42 #4-40 KEP nut (lockwasher attached)	615244
		4 #4-40 x 3/4" self tapping screw	612201
		2 #4 ground lug	639311
<i>#2 Hardware Assembly</i> 997190			
		14 #6-32 x 1/2" machine screw	611385
		14 #6-32 KEP nut (lockwasher attached)	615304
		10 #6-32 x 1/4" self tapping screw (black)	613349
		11 3/8" nut	614065
		4 3/8" spacer	660261
		4 #10-32 x 3/8" SEMS screw (lockwasher attached)	613564
		4 #10 ground lug	639309

SCA-50 FUNCTIONAL BLOCK DIAGRAM

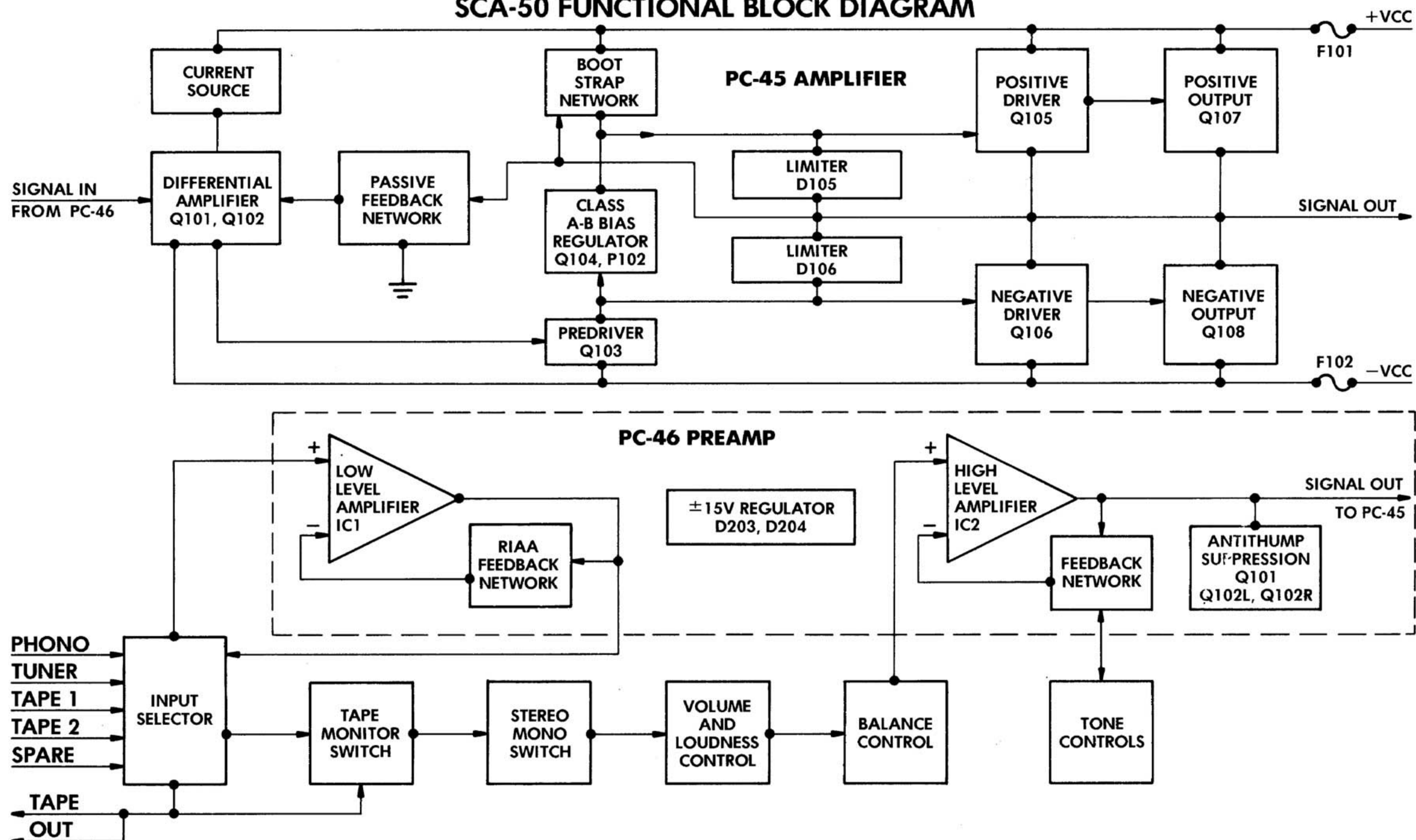

CIRCUIT DESCRIPTION

The components in the SCA-50 have been selected to protect against failure, and all parts are operated conservatively to assure proper operation for many years. All the semiconductors have been selected for minimum noise and distortion, and the printed circuit boards have been pre-tested and adjusted to ensure that every unit will meet or exceed its specifications.

The preamplifier section, PC-46, consists of two active low noise circuit elements, both employing identical integrated circuits with Class A output. They are driven from a regulated ± 15 VDC power supply; D203 and D204 function as the shunt voltage regulators.

The phono preamplifier-equalizer IC201 has a gain of 37 dB @ 1 kHz with standard RIAA equalization, and all feedback is DC connected. The input impedance is flat across the audio band, and therefore it cannot affect the response of the cartridge. Input overload is 100 millivolts or greater, to assure undistorted operation with a wide range of cartridges.

The tone control-output section IC202 uses constant DC feedback in all modes; only AC feedback is altered for tone control operation. The gain is 19 dB with the tone controls out of circuit.

Potentially annoying turn-on and turn-off noises are attenuated at the output of the tone control-output section by the low "on" resistance of the FET, Q202. During normal (on) operation of the SCA-50, Q202 is biased "off". Q202's gate signal is fed from Q201. The time constants and divider networks are selected so that, at turn-on and supply turn-off, Q202 will be in its normal "on" state.

The amplifier stages are fully DC coupled, with a differential pair for the input, and a fully complementary output stage. Its power supply is a full wave bridge with 5,000 mfd

capacitors on both the "+" and "-" supplies to provide excellent filtering and dynamic load stability. Protection includes two separate power supply fuses for each channel, current limiting, a thermal breaker to shut down the amplifier in case of high temperature, and an AC line fuse.

Transistors Q101 and Q102 form a differential pair; they are fed by a current source which is fast at turn-on and slow at turn-off to reduce thumps from the amplifier stage. Potentiometer P101 adjusts the reference voltage for the base of Q101, which in turn balances transistors Q101 and Q102 to control the DC offset of the amplifier.

Transistor Q104 and potentiometer P102 form an adjustable bias supply to eliminate crossover notch. Q104 is attached to the heat sink so that it will thermally track the driver and output transistors, to provide compensation for the bias as the temperature changes.

The driver and output stages of the SCA-50 are a fully complementary configuration. Transistors Q105 and Q107 form a Darlington pair for the positive half of the signal, and transistors Q106 and Q108 form another Darlington pair for the negative half of the signal.

For protection, diode D105 limits the current available in the negative half cycle, and diode D106 limits the positive half cycle—should the speaker load be too low an impedance. In addition, each amplifier channel has its own B+ and B- fuses to protect from excessive current, such as being driven into a short or a very low load impedance. This type of protection causes no unusual noises, and the diodes D105 and D106 keep the current within safe limits.

If the heat sink temperatures of the two channels rises to 80°C, a thermal breaker will shut down the amplifier until the heat sink cools down.

