

PAT-5 PREAMP POWER ON/OFF MUTE



INSTALLATION MANUAL

© 2020 Akitika, LLC
All rights reserved
Revision 1p09 August 5, 2020

Table of Contents

Table of Contents	2
Table of Figures	2
Section 1: About This Manual	3
Who Should Attempt these Projects?	3
Tools and Supplies You'll Need	3
Recommended Solder	4
Project Overview	4
Important Safety Notes	4
Section 2: Building the PCB	5
Overview	5
Use a Soup Bowl	5
Install the resistors	6
Install the diodes	6
Install the LED	6
Install the Relay	7
Install the Transistors	7
Install the Electrolytic capacitors	7
Install wires on the new boards	7
Section 3: Installing the Mute board	8
Remove the Cover	8
Installing the Mounting Brackets	8
Remove these wires from the line-stage boards	9
Solder these wires to the new (mute) board	9
Connect these mute pcb board wires to the line stage boards	9
Mount the mute PCB	9
Rewire the power	10
Final Sanity Checks	13
Voltage checks	13
Timing Checks	13
Power Savings	13
Prepare to Reconnect your PAT-5 to your Music System	13
Appendix 1: The Toothpick Trick	15

Table of Figures

Figure 1-Use a soup bowl with the contents of 1 channel envelope to build 1 channel	5
Figure 2-Silk screen (component) side of PCB	5
Figure 3-LED Orientation	6
Figure 4-Replacing nuts with mounting brackets	8
Figure 5-Mute board installed	9
Figure 6-Power wiring change	10
Figure 7-making a smooth splice	12
Figure 8-wire is spliced and fuse has an empty terminal	12
Figure 9-Schematic of PAT-5 mute board	14

Section 1: About This Manual

This manual gives the information you need to add a power on/off mute function to the PAT-5 Preamp. Please allow me to tell you the story of how this came about.

- When the PAT-5 first came out, the power switch was wired to turn the preamp power on and off. In an early review, perhaps it was Hirsch Houck labs or Stereo Review, they noted that upon turn-on and turn-off, there were large transients. Those transients, played through a large power amp, could wreak havoc on your speakers.
- Now, this certainly could have been addressed by a note that said:
 - turn your power amp on after you've turned the preamp on
 - turn your power amp off before you turn the preamp off
- Dynaco instead chose the answer in all PAT5's...they changed directions so that the power switch was re-wired to only control the convenience outlets. The preamp itself is always powered.
- This kit adds a power-on/off mute function. This allows you to re-wire the power so that the preamp circuits are actually powered up/down with the power switch. The mute relay suppresses start up and turn-off transients, making this arrangement safe.
- The time delay is about 10 seconds after turn-on.
- This kit has only been tested for compatibility with the Updated dynaco updated power supply, line stage, and phono preamp boards.
- While turn-on and turn-off will be silent, ***changes in the selector switch setting during the first 30 seconds after sound comes on may produces output clunks.*** These clunks can be avoided by turning down the volume before changing the input selector. After those first 30 seconds, all the capacitors are charged and settled, and selector switch changes will be clunk-free.

Who Should Attempt these Projects?

You can build this kit if you can:

1. solder (using normal rosin core solder and a soldering iron),
2. use simple hand tools like screwdrivers, wire cutters, and pliers, and
3. read and follow directions.

It helps if you:

1. know a bit about electronics, or
2. have a friend who knows a bit about electronics
3. can get to YouTube to watch a few helpful videos about the assembly process (not available as of this version of the manual)

Tools and Supplies You'll Need

You'll need the following tools:

1. flat blade screwdrivers for #4 and #6 screws, #2 Philips head screwdriver
2. needle nose pliers (helpful, but not strictly necessary)
3. pencil type soldering iron of 25 to 50 Watts (no huge honking soldering guns or blowtorches)
4. wire cutters and strippers

5. de-soldering tools (see Appendix 1)
6. Magnifying glass, if you're over 42!
7. A multi-meter for measuring Ohms and DC volts is a *really good idea*. With it, you can double-check your reading of the color code, making sure you get the right resistors in the right location.

Recommended Solder

The kit must be assembled with 60/40 Rosin Core solder. The recommended diameter is 0.032 inches.

Project Overview

Broadly, the project consists of the following steps:

1. Building the new circuit board.
2. Unplugging the PAT-5 and removing the cover.
3. Installing the newly built circuit board.
4. Reassembling the PAT-5.

Important Safety Notes

By purchasing, using, or assembling this kit, you have agreed to hold AkitikA, LLC harmless for any injuries you may receive in its assembly and/or use. To prevent injuries:

- Wear safety glasses when soldering to prevent eye injuries.
- Always unplug the power before working on the equipment.
- Large capacitors hold lots of energy for a long time. Before you put your hands into the equipment:
 - Pull the AC plug!
 - Wait 1 full minute for the capacitors to discharge!
- Remove jewelry and rings from your hands and wrists, or anything that might dangle into the amplifier.
- If working in the amplifier, keep one hand in your pocket, especially if you're near the power supply or power supply wires. This can prevent serious shocks.
- Build with a buddy nearby. If you've ignored all the previous advice, they can dial 911 or get you to the hospital.

Section 2: Building the PCB

Overview

As you build this PCB, you will:

- Install the indicated component from the component (silk-screen) side.
- Solder the component on the solder side of the PCB.
- Make a check-mark as you complete the step.

You may find it convenient to install all resistors of one value first, as they will usually (but not always) be found taped together.

You'll begin with the components that sit closest to the board, and eventually move to the taller components. Begin with the resistors.

Use a Soup Bowl

Empty the contents of parts envelopes into a broad, flat soup bowl. It will make it easier to find the parts. This makes building the PC boards more pleasant. It also minimizes the chance of losing a part on the floor.



Figure 1-Use a soup bowl with the contents of 1 channel envelope to build 1 channel

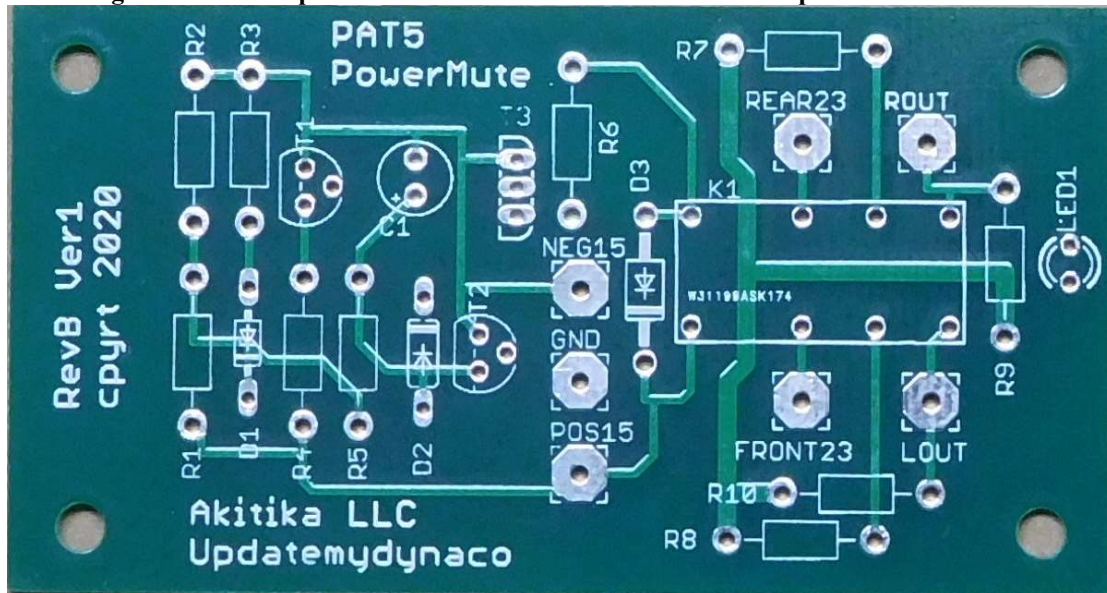

Figure 2-Silk screen (component) side of PCB

Install the resistors

If you'd like to use a lead-bender for the resistors, 0.4" works well for all the resistors. I strongly recommend using good light, magnification if necessary, and a digital ohm-meter to verify the correct resistor value before you install it.

Desig	Value	Color Code	Done ✓
R1	24K9	Red, Yellow, White, Red, Brown	
R2	20K0	Red, Black, Black, Red, Brown	
R3	100K	Brown, Black, Black, Orange, Brown	
R9	100K	Brown, Black, Black, Orange, Brown	
R10	100K	Brown, Black, Black, Orange, Brown	
R4	1 Meg	Brown, Black, Black, Yellow, Brown	
R5	1 Meg	Brown, Black, Black, Yellow, Brown	
R6	499	Yellow, White, White, Black, Brown	
R7	1K00	Brown, Black, Black, Brown, Brown	
R8	1K00	Brown, Black, Black, Brown, Brown	

Install the diodes

The polarity of the diodes matters! Make sure that the banded end of the diode matches the banded end of the silk-screen symbol.

Desig	Value	Identification	Done ✓
D1	10V Zener	B10, glass body	
D2	100 volt switching diode	48, glass body	
D3	400 Volt 1 Amp diode	1N4004, black body	

Install the LED

The LED is polarized, so its orientation is critical! Fresh out of the parts bowl, you'll notice that one lead is longer than the other.

- The longer lead is the anode (positive lead)
- The shorter lead is the cathode (negative lead)

On many LEDs, but not all, you'll also see that there is a flat side on the cathode (negative, short lead) side of the package. Still the most reliable way to identify the polarity is by the longer lead.

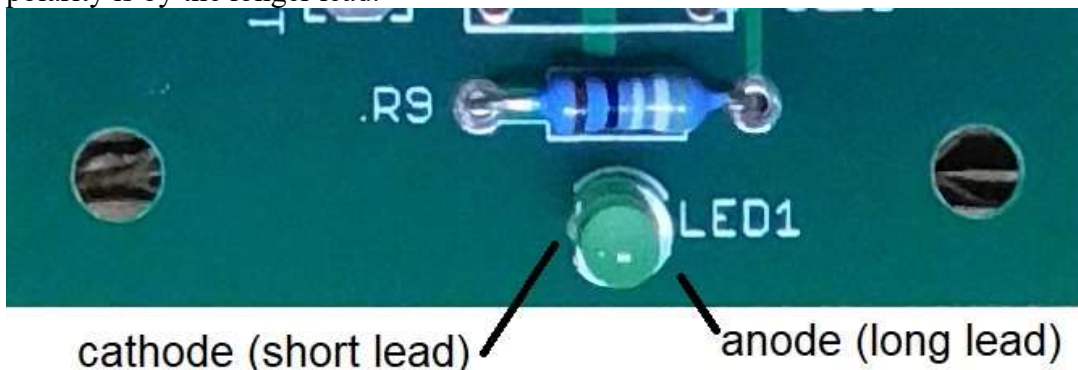

Figure 3-LED Orientation

Install the Relay

Here's the recommended procedure for installing the relay.

1. Place the relay into the board.
2. For now, just solder two corner pins.
3. Check the relay to make sure that it sits flat on the board and that all the pins are projecting thru the PCB.
4. If the relay doesn't sit flat, then melt the solder on the corner pins, one at a time, as you press the relay down to the PCB.
5. Once you're sure that the relay sits flat on the board, solder the rest of the pins.

Install the Transistors

Make sure to match the shape of the transistor body to the outline on the silk screen.

Desig	Value	Marking ¹	Done ✓
T1	2N3904, 60 volt NPN	3904	
T2	2N3904, 60 volt NPN	3904	
T3	ZVN2110A, 100 volt N channel MOSFET	2110	

Install the Electrolytic capacitors

Electrolytic capacitors are polarized. You must observe the correct polarity. Make sure that the negative sign on the capacitor is at the ***opposite*** end from the ***positive sign*** on the silk-screen.

Desig	Value	Done ✓
C1	47 μ F@50 Volts or 35 Volts, either is OK	

Install wires on the new boards

Cut the indicated lengths of the following wires:

- 4" of Red 22 AWG solid, will be used to make +15V connection.
- 2.5" of Black 22 AWG solid, will be used to make ground connection.
- 3.5" of Blue 22 AWG solid, will be used to make -15V connection
- 4.5" of Purple 22 AWG solid, will connect to front line card eyelet 23
- 4.25" of Orange 22 AWG solid, will connect to rear line card eyelet 23

Remove 1/4" of insulation from the ends of each wire. Insert the wires into the solder side and solder them on the component side of the new PCB.

- Red into the POS15 eyelet
- Black into the GND eyelet
- Blue into the NEG15 eyelet
- Purple into the FRONT23 eyelet
- Orange into REAR23 eyelet

This completes assembly of the mute board and all the pre-wiring that can be done. Please inspect your work to verify:

¹ There may be more numbers and letters on the package, but the presence of these numbers is enough to correctly identify these parts.

- Resistor values
- Diode polarities
- Electrolytic capacitor polarities
- That all component leads have been soldered

In the next section, you will open your PAT-5 and install the mute board.

Section 3: Installing the Mute board

If your PAT-5 has the original Dynaco power supply, you must change it out for the Updatemydynaco power supply, Rev E or later.

If your PAT-5 has the Updatemydynaco power supply, Rev D or earlier, then you'll have to apply the PAT5EUP kit.

Remove the Cover

1. Disconnect the PAT-5 from your music system.
2. Unplug the power cord and allow the PAT-5 to sit for one minute before moving on.

Caution: Be sure that the power is unplugged! 120 VAC can be lethal! 240 VAC can be lethal!

3. Remove the 5 screws that hold the cover in place, 2 on the left side, 2 on the right side, and one in the center of the back cover. Do you need more screws? Here's a link: <https://www.updatemydynaco.com/storeindex.html#5CS>
4. Lift the cover straight up and set it aside in a safe place.

Installing the Mounting Brackets

Remove the two sets of 4-40 screws and nuts that hold the left-top end of the line-stage boards in place. Replace the nuts with the small supplied brackets as shown in Figure 4.



Figure 4-Replacing nuts with mounting brackets

Remove these wires from the line-stage boards

- Desolder the wire from eyelet 23 of the rear line stage PCB. Label it with an ROUT label.
- Desolder the wire from eyelet 23 of the front line-stage PCB. Label it with an LOUT label.

Solder these wires to the new (mute) board

- ROUT labeled wire to the ROUT eyelet of the new PCB. Insert the wire into the solder side and solder it on the component side.
- LOUT labeled wire to the LOUT eyelet of the new PCB. Insert the wire into the solder side and solder it on the component side.

Connect these mute pcb board wires to the line stage boards

- Black wire into the front line-stage board, eyelet 4. Insert it into the solder side and solder it on the component side. This is a connection to ground.
- Blue wire into the front line-stage board, eyelet 16. Insert it into the solder side and solder it on the component side. This is a connection to negative 15 volts.
- Red wire into the front line-stage board, eyelet 19. Insert it into the solder side and solder it on the component side. This is a connection to positive 15 volts.
- Purple wire into the front line-stage board, eyelet 23. Insert it into the solder side and solder it on the component side.
- Orange wire into the rear line-stage board, eyelet 23. Insert it into the component side and solder it on the solder side.

Mount the mute PCB

Dress the leads down and line up the mounting holes in the PCB with the new brackets. Use the two 4-40x1/4” sems screws (with built-in lock washers) to mount the board in place. The board may have to be angled up a bit, as its fit between the existing line cards might be hampered by non-parallel line cards.

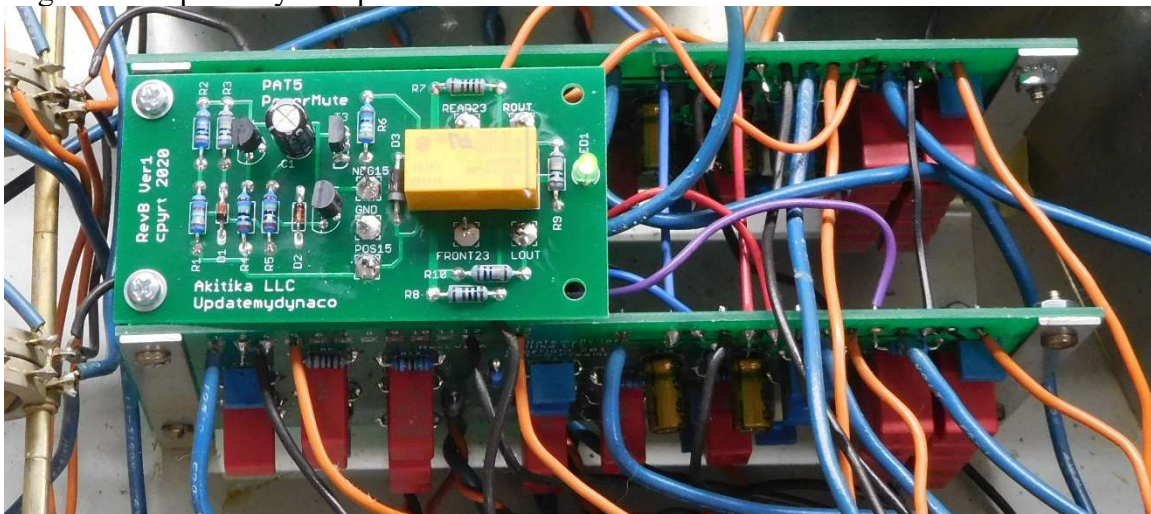

Figure 5-Mute board installed

Rewire the power

Why were we doing all of this? So that turning off the power switch would be possible without large, speaker damaging transients. Thus we are at a truly important step. We will now re-wire the power switch to control power applied to the power transformer.

Make sure that the preamp is unplugged before you continue!

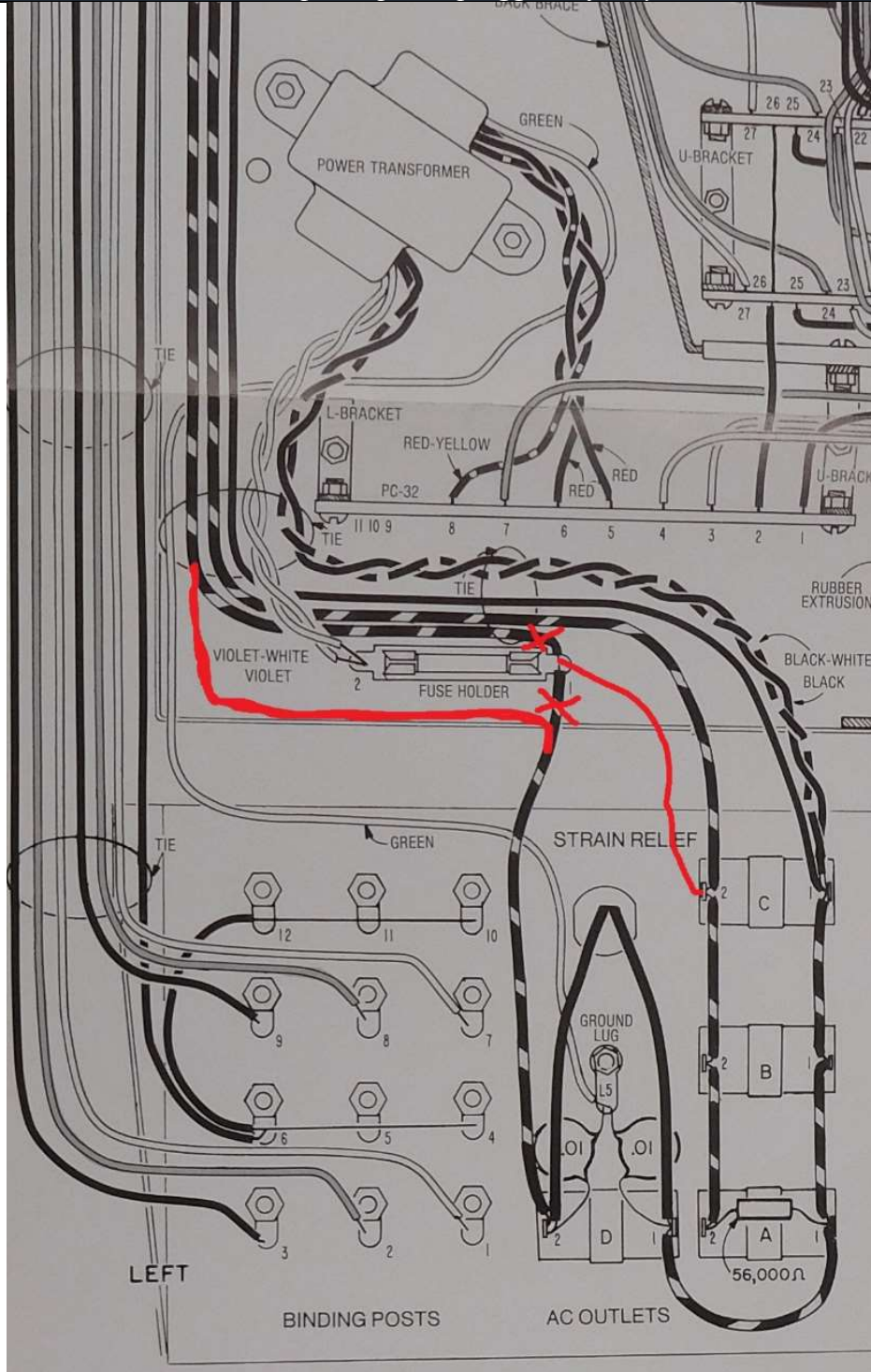

Figure 6-Power wiring change

1. Remove the fuse.
2. Remove the screw that holds the fuse holder to the chassis. This will give you access to the two wires that connect to fuse-holder pin 1.



3. Desolder both wires from fuse terminal 1. Use the supplied heat-shrink tubing to reconnect those two wires, temporarily leaving fuse terminal 1 open:
 - a. Slide a 2" long piece of heat-shrink tubing over the wire that runs to the switch, moving it back from the cut end so it won't start to shrink prematurely.
 - b. Strip back the ends of both wires to reveal 1/2" virgin unsoldered copper on each wire. Cross the wires at the half-way point at a 45-degree angle
 - c. Twist those ends together as shown in the picture below. Your goal is to make a smooth splice with no sharp points. Figure 7-making a smooth splice. Figure 7 shows the method with a piece of red wire I had laying around. The color of the wires that you splice will certainly be different! Just identify them carefully from Figure 6, where we have used red marks to show:
 - i. The effect of the splice
 - ii. Isolating off the terminal of the fuse,
 - iii. Reconnecting the terminal of the fuse, as will happen in the next steps.

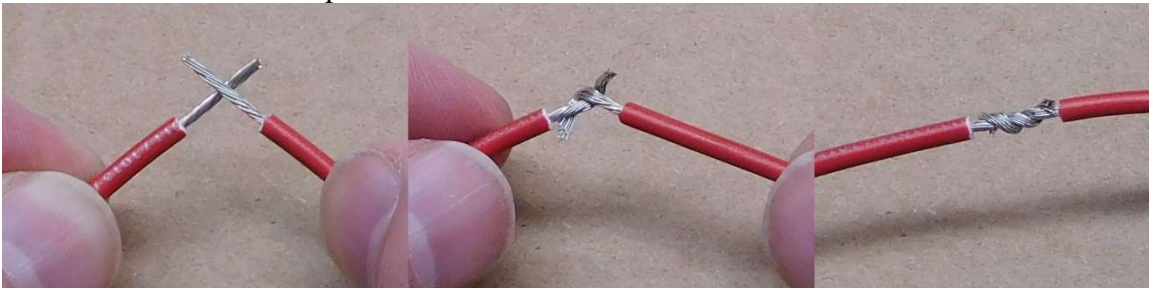

Figure 7-making a smooth splice

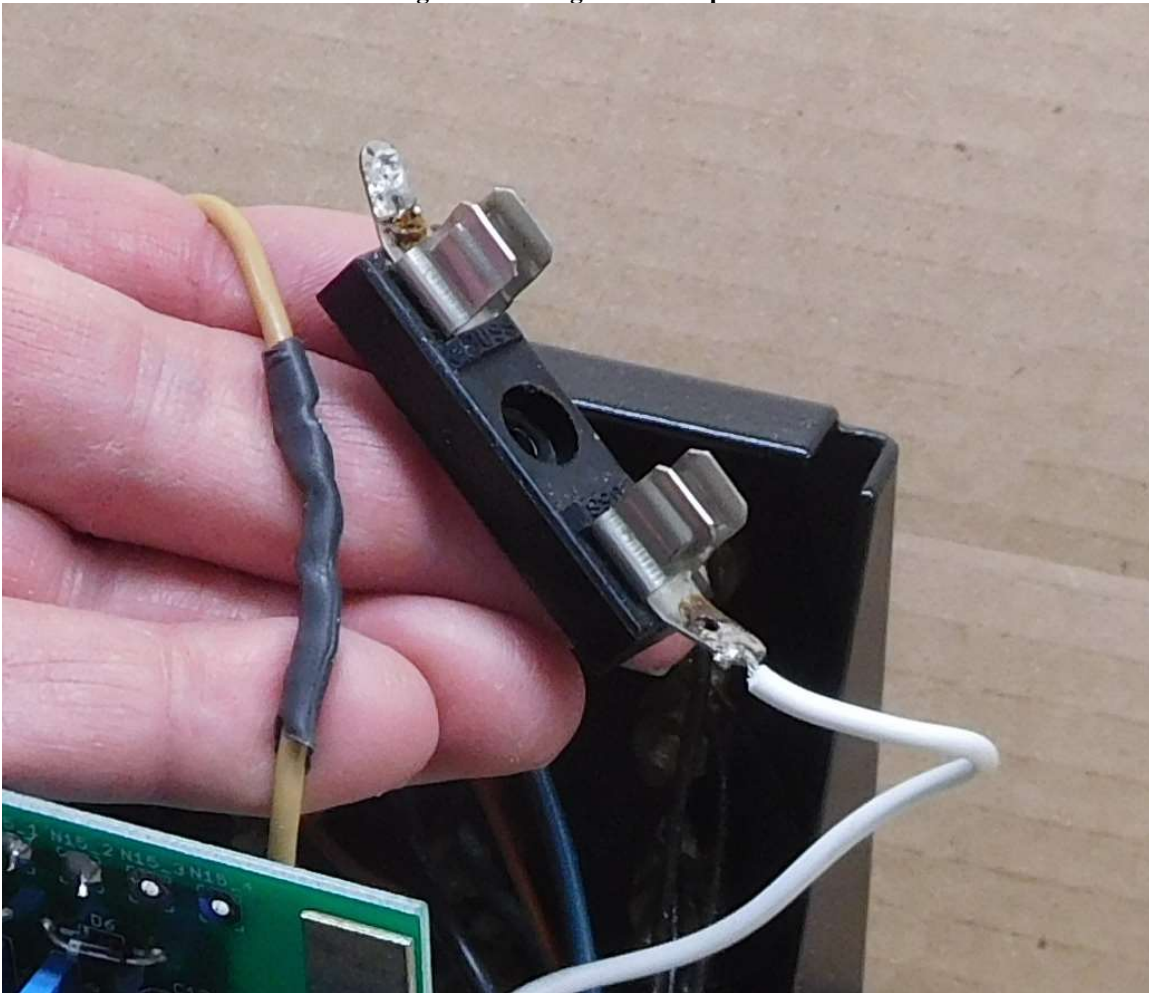

Figure 8-wire is spliced and fuse has an empty terminal

4. Cut a 5" piece of the supplied 22 AWG black wire. Strip 3/8" of insulation from both ends.
 - a. Crimp and solder one end of the wire to the empty fuse terminal.
 - b. Crimp and solder the other end of the wire to pin 2 of one of convenience outlets A, B, and C (Refer to Figure 6, connect to whichever one is convenient!).
5. Reinstall the fuse holder.
6. Reinstall the fuse.

Final Sanity Checks

Voltage checks

Here are a few last tests *before* you reconnect your PAT-5 to your music system. With the top still off, plug in the AC mains. Turn the power switch on. Set your meter to DC volts. Measure the following voltages on the newly installed mute board.

<i>Be careful! These steps are performed with the power connected and turned on!</i>	Done ✓	Done ✓
The voltage from the POS15 to ground should measure +15 +/-1 Volts (with respect to ground).	<input type="checkbox"/>	<input type="checkbox"/>
The voltage from the NEG15 to ground should measure +15 +/-1 Volts (with respect to ground).	<input type="checkbox"/>	<input type="checkbox"/>

If your voltage readings are significantly different, it could indicate either a power supply problem, or a problem with your re-assembled PCB's. Re-inspect your work, looking for disconnected or swapped wires.

Turn the power switch off. Repeat your voltage tests. The voltages should have dropped substantially to zero if the switch rewiring is correct.

Timing Checks

Begin with the power switch off. Turn the power switch on, and time how long it takes for the LED to turn on. It should be around 10 seconds.

Beginning with the LED on, turn off the power switch. The LED should turn off in about 1 second.

Power Savings

We've now reached the object of this project, to have the power switch control the power to the power supply. Assuming that the preamp takes 10 Watts, the savings would be about \$8.50 per year.

Prepare to Reconnect your PAT-5 to your Music System

- Turn off the power.
- Remove the AC plug from the wall socket.
- Replace the cover. Before you test your work, it's important to replace the cover. Without the cover in place, there will likely be a lot of hum. With the cover in place, the PAT-5 quiets down very nicely (unless of course you have power supply problems).
- Reinstall the five screws that hold the cover in place.
- Reinstall the PAT-5 to your music system.

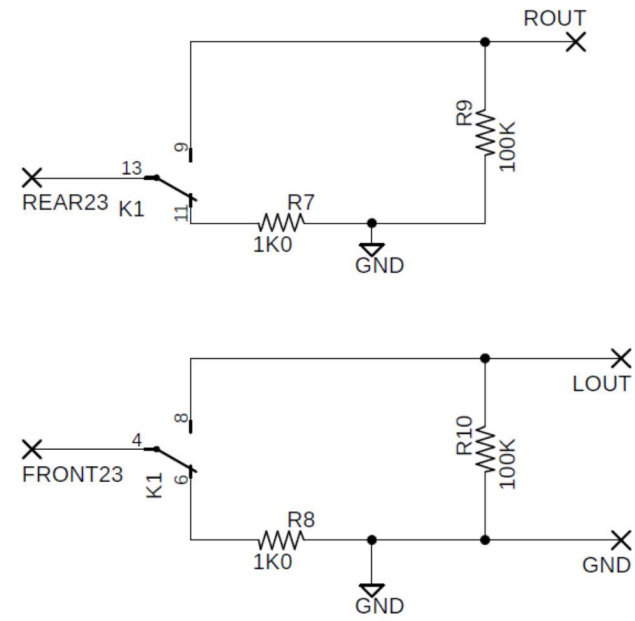
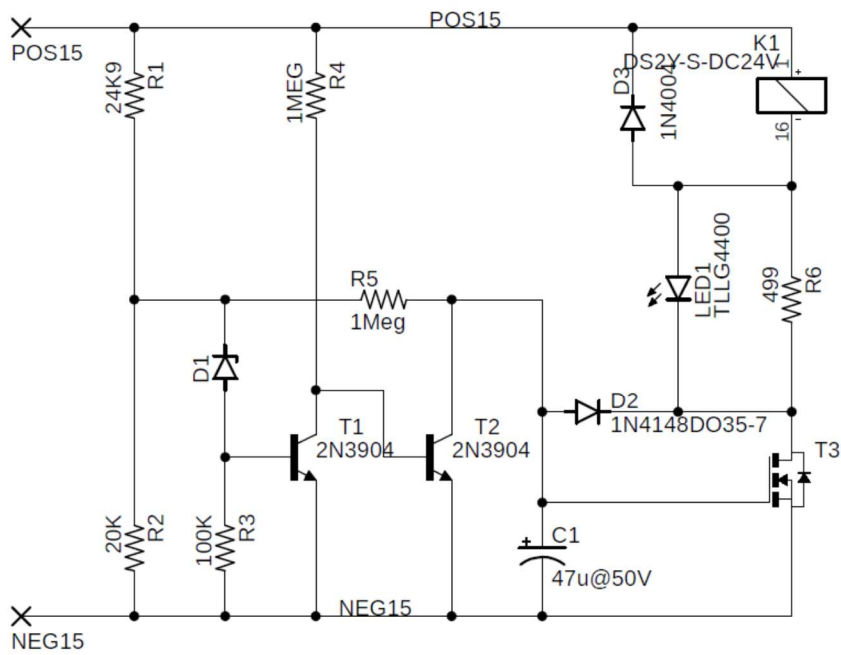

Figure 9-Schematic of PAT-5 mute board

Appendix 1: The Toothpick Trick

This appendix describes an easy way to clear the solder from a hole in the PCB. It can also be used to clear the solder from terminals on pots or jacks. Doing so makes it easier to install a new component, or reinstall wires that were temporarily removed to allow access to some other component.

All you'll need is a soldering iron and some toothpicks with sharp points. The diameter of the pointed part of the toothpick must be smaller than the diameter of the hole that you're trying to clear.

Heat the solder land on the component side of the board until the solder flows. Insert the toothpick from the component side of the board while pushing and twisting the toothpick. If the solder has melted, the toothpick should push through the board, displacing the solder. Remove the soldering iron, but let the toothpick remain in the hole until the solder has solidified. Now remove the toothpick. There should be a hole through the solder sufficiently large to allow you to insert the component lead or wire.

Sometimes, a bit of the toothpick will break off in the hole. If this happens, use a stiff piece of wire to push the toothpick fragment out of the hole.